

The image features three large tower cranes in silhouette against a dramatic sunset sky. The cranes are positioned at different heights and angles, creating a sense of depth and scale. The sky is a mix of soft pinks, oranges, and purples, with some clouds catching the low light. The overall mood is industrial yet serene.

MULTI SUPPLIES GROUP

MSG EGYPT

CONTENTS

CONTENTS

GREEN PIN SHACKLES	05
POLYESTER SLINGS	11
WIRE ROPE	13
GROMMET SLINGS	17
PP ROPE	19
MANUAL HOIST	21
LEVER HOIST	23
WIRE ROPE PULLER	25
LOAD BINDER	27
BEAM CLAMP	29
MAGNETIC LIFTER	30
LIFTING CHAIN	31
CARGO LASHING	32
MASTER LINK	33
MASTER LINK ASSEMBLY	34
CLEVIS HOOK	35
GRAB HOOK	37

EYE SLING HOOK	39
SHORTENING CLUTCH	40
LIFTMAN SHACKLES	41
TURNBUCKLE	45
WIRE ROPE CLIP	49
ELECTRIC CHAIN HOIST	50
STAINLESS STEEL CHAIN SLINGS	55
FALL PROTECTION	59
BRAND PARTNERS	68
CHAIN SLINGS CHART	69





G-4161

Green Pin® Standard Shackles Bow Shackles with Screw Collar Pin

- Material** : Bow and pin high tensile steel, Grade 6, quenched and tempered
- Safety Factor** : MBL equals 6 x WLL
- Standard** : EN 13889 and meets performance requirements of US Fed. Spec. RR-C-271 Type IVA Class 2, Grade A
- Finish** : hot dipped galvanized
- Temperature Range** : -20°C up to +200°C
- Certification** : At no extra charges this product can be supplied with a works certificate, 3.1 material certificate, manufacturer test certificate, EC Declaration of Conformity and all shackles starting from 2 t can be supplied with DNV 2.7-1 certificate.
- Note** : For details on dimensions and tolerances please consult our CAD drawings, these are available on request.

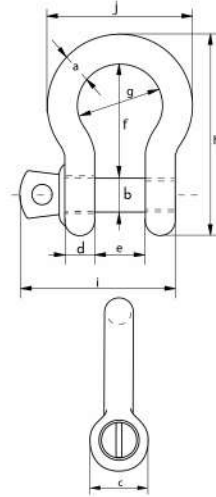

working load limit	diameter bow	diameter pin	diameter eye	width eye	width inside	length inside	width bow	length	length bolt	width	weight each
t	a mm	b mm	c mm	d mm	e mm	f mm	g mm	H mm	i mm	j mm	kg
0.33	5	6	12	5	9.5	22	16	36	29.5	26	0.02
0.5	7	8	16.5	7	12	29	20	48.5	38	34	0.05
0.75	9	10	20	9	13.5	32	22	56	46.5	40	0.1
1	10	11	22.5	10	17	36.5	26	63.5	54	46	0.14
1.5	11	13	26.5	11	19	43	29	74	59.5	51	0.19
2	13.5	16	34	13	22	51	32	89	73	58	0.36
3.25	16	19	40	16	27	64	43	110	89	75	0.63
4.75	19	22	46	19	31	76	51	129	103	89	1.01
6.5	22	25	52	22	36	83	58	144	119	102	1.5
8.5	25	28	59	25	43	95	68	164	137	118	2.21
9.5	28	32	66	28	47	108	75	185	153	131	3.16
12	32	35	72	32	51	115	83	201	170	147	4.31
13.5	35	38	80	35	57	133	92	227	186	162	5.55
17	38	42	88	38	60	146	99	249	203	175	7.43
25	45	50	103	45	74	178	126	300	243	216	12.84
35	50	57	111	50	83	197	138	331	272	238	18.15
42.5	57	65	130	57	95	222	160	377	310	274	26.29
55	65	70	145	65	105	260	180	433	344	310	37.6

■ In inch

working load limit	diameter bow	diameter pin	diameter eye	width eye	width inside	length inside	width bow	length	length bolt	width	weight each
t	a inch	b inch	c inch	d inch	e inch	f inch	g inch	H inch	i inch	j inch	lbs
0.33	3/16	1/4	1/2	3/16	3/8	7/8	5/8	1 13/32	1 5/32	1 1/32	0.05
0.5	1/4	5/16	21/32	9/32	15/32	1 5/32	29/32	2 29/32	1 1/2	1 11/32	0.11
0.75	5/16	3/8	25/32	11/32	17/32	1 1/4	7/8	2 7/32	1 27/32	1 9/16	0.22
1	3/8	7/16	7/8	13/32	21/32	1 7/16	1 1/32	2 1/2	2 1/8	1 13/16	0.3
1.5	7/16	1/2	1 1/32	7/16	3/4	1 11/16	1 5/32	2 29/32	2 11/32	2	0.42
2	1/2	5/8	1 11/32	1/2	7/8	2	1 1/4	3 1/2	2 7/8	2 9/32	0.79
3.25	5/8	3/4	1 9/16	5/8	1 1/16	2 17/32	1 11/16	4 11/32	3 1/2	2 15/16	1.38
4.75	3/4	7/8	1 13/16	3/4	1 7/32	3	2	5 3/32	4 1/16	3 1/2	2.22
6.5	7/8	1	2 1/16	7/8	1 13/32	3 9/32	2 9/32	5 21/32	4 11/16	4 1/32	3.31
8.5	1	1 1/8	2 5/16	31/32	1 11/16	3 3/4	2 11/16	6 15/32	5 13/32	4 21/32	4.86
9.5	1 1/8	1 1/4	2 19/32	1 3/32	1 27/32	4 1/4	2 15/16	7 9/32	6 1/32	5 5/32	6.97
12	1 1/4	1 3/8	2 27/32	1 1/4	2	4 17/32	3 9/32	7 29/32	6 11/16	5 25/32	9.49
13.5	1 3/8	1 1/2	3 5/32	1 3/8	2 1/4	5 1/4	3 5/8	8 15/16	7 5/16	6 3/8	12.24
17	1 1/2	1 5/8	3 15/32	1 1/2	2 3/8	5 3/4	3 29/32	9 13/16	8	6 7/8	16.37
25	1 3/4	2	4 1/16	1 25/32	2 29/32	7	4 31/32	11 13/16	9 9/16	8 1/2	28.31
35	2	2 1/4	4 3/8	1 31/32	3 9/32	7 3/4	5 7/16	13 1/32	10 29/32	9 3/8	40.01
42.5	2 1/4	2 9/16	5 1/8	2 1/4	3 3/4	8 3/4	6 5/16	14 27/32	12 7/32	10 25/32	57.96
55	2 1/2	2 3/4	5 23/32	2 9/16	4 1/8	10 1/4	7 3/32	17 1/16	13 17/32	12 7/32	82.89



G-4163

Green Pin® Standard Shackles Bow Shackle Safety Bolt Type

- Material** : Bow and pin high tensile steel, Grade 6, quenched and tempered
- Safety Factor** : MBL equals 6 x WLL
- Standard** : EN 13889 and meets performance requirements of US Fed. Spec. RR-C-271 Type IVA Class 2, Grade A
- Finish** : hot dipped galvanized
- Temperature Range** : -20°C up to +200°C
- Certification** : At no extra charges this product can be supplied with a works certificate, 3.1 material certificate, manufacturer test certificate, EC Declaration of Conformity and all shackles starting from 2 t can be supplied with DNV 2.7-1 certificate.
- Note** : For details on dimensions and tolerances please consult our CAD drawings, these are available on request.

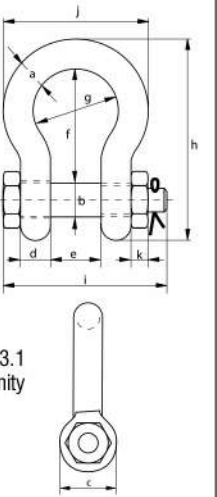

working load limit	diameter bow	diameter pin	diameter eye	width eye	width inside	length inside	width bow	length	length bolt	width	thickness nut	weight each
t	a mm	b mm	c mm	d mm	e mm	f mm	g mm	h mm	i mm	j mm	k mm	kg
0.5	7	8	16.5	7	12	29	20	48.5	42	34	4	0.06
0.75	9	10	20	9	13.5	32	22	56	50	40	5	0.11
1	10	11	22.5	10	17	36.5	26	63.5	60	46	8	0.16
1.5	11	13	26.5	11	19	43	29	74	67	51	11	0.22
2	13.5	16	34	13	22	51	32	89	82	58	13	0.42
3.25	16	19	40	16	27	64	43	110	98	75	17	0.74
4.75	19	22	46	19	31	76	51	129	114	89	19	1.18
6.5	22	25	52	22	36	83	58	144	130	102	22	1.77
8.5	25	28	59	25	43	95	68	164	150	118	25	2.58
9.5	28	32	66	28	47	108	75	185	166	131	27	3.66
12	32	35	72	32	51	115	83	201	178	147	30	4.91
13.5	35	38	80	35	57	133	92	227	197	162	33	6.54
17	38	42	88	38	60	146	99	249	202	175	39	8.19
25	45	50	103	45	74	178	126	300	249	216	43	14.22
35	50	57	111	50	83	197	138	331	269	238	49	19.85
42.5	57	65	130	57	95	222	160	377	301	274	55	28.33
55	65	70	145	65	105	260	180	433	330	310	62	39.59
85	75	83	162	73	127	329	190	527	380	340	71	62

■ In inch

working load limit	diameter bow	diameter pin	diameter eye	width eye	width inside	length inside	width bow	length	length bolt	width	thickness nut	weight each
t	a inch	b inch	c inch	d inch	e inch	f inch	g inch	h inch	i inch	j inch	k inch	lbs
0.5	1/4	5/16	21/32	9/32	15/32	1 5/32	25/32	1 29/32	1 21/32	1 11/32	5/32	0.13
0.75	5/16	3/8	25/32	11/32	17/32	1 1/4	7/8	2 7/32	1 31/32	1 9/16	3/16	0.25
1	3/8	7/16	7/8	13/32	21/32	1 7/16	1 1/32	2 1/2	2 1/8	1 13/16	5/16	0.34
1.5	7/16	1/2	1 1/32	7/16	3/4	1 11/16	1 5/32	2 29/32	2 5/8	2	7/16	0.48
2	1/2	5/8	1 11/32	1/2	7/8	2	1 1/4	3 1/2	3 7/32	2 9/32	1/2	0.92
3.25	5/8	3/4	1 9/16	5/8	1 1/16	2 17/32	1 11/16	4 11/32	3 27/32	2 15/16	21/32	1.62
4.75	3/4	7/8	1 13/16	3/4	1 7/32	3	2	5 3/32	4 1/2	3 1/2	3/4	2.59
6.5	7/8	1	2 1/16	7/8	1 13/32	3 9/32	2 9/32	5 21/32	5 1/8	4 1/32	7/8	3.9
8.5	1	1 1/8	2 5/16	31/32	1 11/16	3 3/4	2 11/16	6 15/32	5 29/32	4 21/32	31/32	5.69
9.5	1 1/8	1 1/4	2 19/32	1 3/32	1 27/32	4 1/4	2 15/16	7 9/32	6 17/32	5 5/32	1 1/16	8.06
12	1 1/4	1 3/8	2 27/32	1 1/4	2	4 17/32	3 9/32	7 29/32	7	5 25/32	1 3/16	10.81
13.5	1 3/8	1 1/2	3 5/32	1 3/8	2 1/4	5 1/4	3 5/8	8 15/16	7 3/4	6 3/8	1 5/16	14.42
17	1 1/2	1 5/8	3 15/32	1 1/2	2 3/8	5 3/4	3 29/32	9 13/16	7 15/16	6 7/8	3/4	18.06
25	1 3/4	2	4 1/16	1 25/32	2 29/32	7	4 31/32	11 13/16	9 13/16	8 1/2	29/32	31.34
35	2	2 1/4	4 3/8	1 31/32	3 9/32	7 3/4	5 7/16	13 1/32	10 19/32	9 3/8	1 1/32	43.77
42.5	2 1/4	2 9/16	5 1/8	2 1/4	3 3/4	8 3/4	6 5/16	14 27/32	11 27/32	10 23/32	1 5/32	62.46
55	2 1/2	2 3/4	5 23/32	2 9/16	4 1/8	10 1/4	7 3/32	17 1/16	13	12 7/32	1 1/4	87.27
85	3	3 1/4	6 3/8	2 7/8	5	12 15/16	7 15/32	20 3/4	14 31/32	13 3/8	1 17/32	136.69



Green Pin® Standard Shackles Dee Shackles with Screw Collar Pin

- Material** : bow and pin high tensile steel, Grade 6, quenched and tempered
- Safety Factor** : MBL equals 6 x WLL
- Standard** : EN 13889 and meets performance requirements of US Fed. Spec. RR-C-271 Type IVA Class 2, Grade A
- Finish** : hot dipped galvanized
- Temperature Range** : -200C up to +2000C
- Certification** : At no extra charges this product can be supplied with a works certificate, 3.1 material certificate, manufacturer test certificate, EC Declaration of Conformity and all shackles starting from 2 t can be supplied with DNV 2.7-1 certificate.

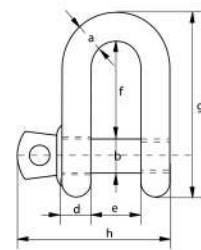

Note : For details on dimensions and tolerances please consult our CAD drawings, these are available on request.

working load limit	diameter bow	diameter pin	diameter eye	width eye	width inside	length inside	length	length bolt	weight each
t	a mm	b mm	c mm	d mm	e mm	f mm	g mm	h mm	kg
0.33	5	6	12	5	9.5	19	33	29.5	0.02
0.5	7	8	16.5	7	12	22	41.5	38	0.05
0.75	9	10	20	9	13.5	26	50	46.5	0.09
1	10	11	22.5	10	17	32	59	54	0.14
1.5	11	13	26.5	11	19	37	68	59.5	0.19
2	13.5	16	34	13	22	43	81	73	0.32
3.25	16	19	40	16	27	51	97	89	0.54
4.75	19	22	46	19	31	59	112	103	0.87
6.5	22	25	52	22	36	73	134	119	1.34
8.5	25	28	59	25	43	85	154	137	2.08
9.5	28	32	66	28	47	90	167	153	2.77
12	32	35	72	32	51	94	180	170	3.72
13.5	35	38	80	35	57	115	209	186	5.14
17	38	42	88	38	60	127	230	203	6.85
25	45	50	103	45	74	149	271	243	11.45
35	50	57	111	50	83	171	305	272	16.86
42.5	57	65	130	57	95	190	345	310	24.61
55	65	70	145	65	105	203	376	344	32.65

■ In inch

working load limit	diameter bow	diameter pin	diameter eye	width eye	width inside	length inside	length	length bolt	weight each
t	a inch	b inch	c inch	d inch	e inch	f inch	g inch	h inch	lbs
0.33	3/16	1/4	15/32	3/16	3/8	3/4	1 5/16	1 5/32	0.04
0.5	1/4	5/16	21/32	9/32	15/32	7/8	1 5/8	1 1/2	0.11
0.75	5/16	3/8	25/32	11/32	17/32	1 1/32	1 31/32	1 27/32	0.2
1	3/8	7/16	7/8	13/32	21/32	1 1/4	2 5/16	2 1/8	0.3
1.5	7/16	1/2	1 1/32	7/16	3/4	1 15/32	2 11/16	2 11/32	0.42
2	1/2	5/8	1 11/32	1/2	7/8	1 11/16	3 3/16	2 7/8	0.7
3.25	5/8	3/4	1 9/16	5/8	1 1/16	2	3 15/16	3 1/2	1.19
4.75	3/4	7/8	1 13/16	3/4	1 7/32	2 5/16	4 12/32	4 1/16	1.92
6.5	7/8	1	2 1/16	7/8	1 13/32	2 7/8	5 9/32	4 11/16	2.95
8.5	1	1 1/8	2 5/16	31/32	1 11/16	3 11/32	6 1/16	5 13/32	4.59
9.5	1 1/8	1 1/4	2 19/32	1 3/32	1 27/32	3 17/32	6 9/16	6 1/32	6.1
12	1 1/4	1 3/8	2 27/32	1 1/4	2	3 11/16	7 3/32	6 11/16	8.2
13.5	1 3/8	1 7/8	3 5/32	1 3/8	2 1/4	4 17/32	8 7/32	7 5/16	11.33
17	1 1/2	1 5/8	3 15/32	1 1/2	2 3/8	5	9 1/16	8	15.1
25	1 3/4	2	4 1/16	1 25/32	2 29/32	5 7/8	10 21/32	9 9/16	25.23
35	2	2 1/4	4 3/8	1 31/32	3 9/32	6 23/32	12	10 23/32	37.17
42.5	2 1/4	2 9/16	5 1/8	2 1/4	3 3/4	7 15/32	13 19/32	12 7/32	54.26
55	2 1/2	2 3/4	5 23/32	2 9/16	4 1/8	8	14 13/16	13 17/32	71.98

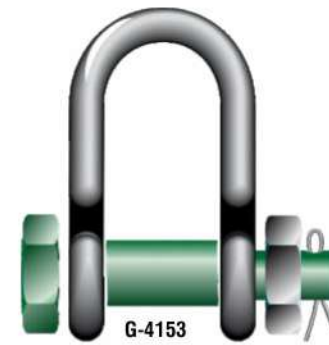

Green Pin® Standard Shackles Dee Shackles with Safety Bolt

- Material** : bow and pin high tensile steel, Grade 6, quenched and tempered
- Safety Factor** : MBL equals 6 x WLL
- Standard** : EN 13889 and meets performance requirements of US Fed. Spec. RR-C-271 Type IVA Class 2, Grade A
- Finish** : hot dipped galvanized
- Temperature Range** : -20°C up to +200°C
- Certification** : At no extra charges this product can be supplied with a works certificate, 3.1 material certificate, manufacturer test certificate, EC Declaration of Conformity and all shackles starting from 2 t can be supplied with DNV 2.7-1 certificate.

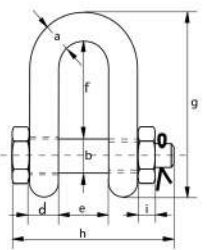

Note : For details on dimensions and tolerances please consult our CAD drawings, these are available on request.

working load limit	diameter bow	diameter pin	diameter eye	width eye	width inside	length inside	length	length bolt	thickness nut	weight each
t	a mm	b mm	c mm	d mm	e mm	f mm	g mm	h mm	i mm	kg
2	13.5	16	34	13	22	43	81	82	13	0.39
3.25	16	19	40	16	27	51	97	98	17	0.67
4.75	19	22	46	19	31	59	112	114	19	1.08
6.5	22	25	52	22	36	73	134	130	22	1.66
8.5	25	28	59	25	43	85	154	150	25	2.46
9.5	28	32	66	28	47	90	167	166	27	3.4
12	32	35	72	32	51	94	180	178	30	4.51
13.5	35	38	80	35	57	115	209	197	33	6.1
17	38	42	88	38	60	127	230	202	19	7.63
25	45	50	103	45	74	149	271	249	23	12.88
35	50	57	111	50	83	171	305	269	26	17.35
42.5	57	65	130	57	95	190	345	301	29	25.94
55	65	70	145	65	105	203	376	330	32	35.33
85	75	83	162	73	127	229	427	380	39	52.97

■ In inch

working load limit	diameter bow	diameter pin	diameter eye	width eye	width inside	length inside	length	length bolt	thickness nut	weight each
t	a inch	b inch	c inch	d inch	e inch	f inch	g inch	h inch	i inch	lbs
2	1/2	5/8	1 11/32	1/2	7/8	1 11/16	3 3/16	3 7/32	1/2	0.85
3.25	5/8	3/4	1 9/16	5/8	1 1/16	2	3 13/16	3 27/32	21/32	1.48
4.75	3/4	7/8	1 13/16	3/4	1 7/32	2 5/16	4 13/32	4 1/2	3/4	2.39
6.5	7/8	1	2 1/16	7/8	1 13/32	2 7/8	5 9/32	5 1/8	7/8	3.66
8.5	1	1 1/8	2 5/16	31/32	1 11/16	3 11/32	6 1/16	5 29/32	31/32	5.42
9.5	1 1/8	1 1/4	2 19/32	1 3/32	1 27/32	3 17/32	6 9/16	6 17/32	1 1/16	7.5
12	1 1/4	1 3/8	2 27/32	1 1/4	2	3 11/16	7 3/32	7	1 3/16	9.95
13.5	1 3/8	1 1/2	3 5/32	1 3/8	2 1/4	4 17/32	8 7/32	7 3/4	1 5/16	13.45
17	1 1/2	1 5/8	3 15/32	1 1/2	2 3/8	5	9 1/16	7 15/16	3/4	16.82
25	1 3/4	2	4 1/16	1 25/32	2 29/32	5 7/8	10 21/32	9 13/16	29/32	28.4
35	2	2 1/4	4 3/8	1 31/32	3 9/32	6 23/32	12	10 19/32	1 1/32	38.25
42.5	2 1/4	2 9/16	5 1/8	2 1/4	3 3/4	7 15/32	13 19/32	11 27/32	1 5/32	57.19
55	2 1/2	2 3/4	5 23/32	2 9/16	4 1/8	8	14 13/16	13	1 1/4	77.89
85	3	3 1/4	6 3/8	2 7/8	5	9 1/32	16 13/16	14 31/32	1 17/32	116.77



Green Pin® Standard Shackles

Sling Shackles with Safety Bolt Type

- Material** : Bow and pin alloy steel, Grade 8, quenched and tempered
- Safety Factor** : MBL equals 5 x WLL
- Finish** : Shackle bow painted silver, pin painted green
- Temperature Range** : -200C up to +2000C
- Certification** : At no extra charges this product can be supplied with a works certificate, 3.1 material certificate, manufacturer test certificate, EC declaration of Conformity and all shackles from 75 t and up are supplied with a Lloyd's Register of Shipping Certificate on proof load. For shackles 75 t and up an MPI and/or US inspection certificate can be supplied on request.

Note : For details on dimensions and tolerances please consult our CAD drawings, these are available on request.

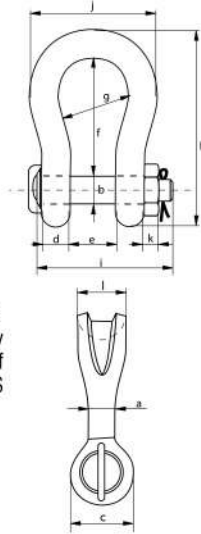

SHACKLES

working load limit	diameter body	diameter pin	diameter eye	width eye	width inside	length inside	width bow	length bow	length bolt	width	thickness nut	bearing surface	weight each
t	a	b	c	d	e	f	g	h	i	j	k	l	kg
18	35	35	69	30	54	148	102	239	171	180	29	64	7
30	40	42	90	35	69	165	126	279	207	200	34	79	13
40	55	51	109	45	84	199	140	331	252	235	38	97	21
55	60	57	115	55	90	240	160	389	294	270	45	100	30
75	68	70	125	54	110	290	185	473	327	317	54	120	48
125	85	80	154	85	137	366	220	583	426	390	64	150	92
150	94	95	179	89	147	391	253	645	435	434	50	170	140
200	110	105	199	100	158	481	280	759	470	482	50	205	205
250	126	120	227	110	179	542	300	859	519	530	60	240	264
300	135	134	245	122	195	601	350	947	575	620	70	265	360
400	160	160	293	145	231	576	370	985	675	690	80	320	580
500	170	180	328	160	263	681	450	1131	748	790	90	339	780
600	190	200	348	170	289	741	490	1234	809	865	100	370	980
700	200	215	392	190	315	751	540	1284	879	901	100	400	1360
800	218	230	420	200	342	851	554	1426	942	947	110	420	1430
900	242	255	466	220	368	851	580	1488	1023	1023	120	440	1650
1000	260	270	490	240	399	851	614	1532	1103	1107	120	460	2970
1250	285	300	510	260	452	931	650	1666	1227	1182	150	530	3700
1550	285	320	550	280	483	950	680	1710	1300	1253	150	560	4000

In inch

working load limit	diameter body	diameter pin	diameter eye	width eye	width inside	length inside	width bow	length bow	length bolt	width	thickness nut	bearing surface	weight each
t	a	b	c	d	e	f	g	h	i	j	k	l	lbs
18	1 3/8	1 3/8	2 23/32	1 3/16	2 1/8	5 13/16	4 1/32	9 13/32	6 25/32	7 3/32	1 5/32	2 17/32	18
30	1 9/16	1 21/32	3 17/32	1 3/8	2 23/32	6 1/2	4 31/32	10 31/32	8 5/32	7 7/8	1 11/32	3 1/8	29
40	2 5/32	2	4 9/32	1 25/32	3 5/16	7 27/32	5 1/2	13 1/32	9 29/32	9 1/4	1 1/2	3 13/16	46
55	2 3/8	2 1/4	4 17/32	2 5/32	3 17/32	9 7/16	6 5/16	15 5/16	11 9/16	10 5/8	1 25/32	3 15/16	66
75	2 11/16	2 3/4	4 29/32	2 1/8	4 11/32	11 13/32	7 9/32	18 5/8	12 7/8	12 15/32	2 1/8	4 23/32	106
125	3 11/32	3 5/32	6 1/16	3 11/32	5 13/32	14 13/32	8 21/32	22 15/16	16 25/32	15 11/32	2 17/32	5 29/32	203
150	3 11/16	3 3/4	7 1/16	3 1/2	5 25/32	15 13/32	9 31/32	25 13/32	17 1/8	17 3/32	1 31/32	6 11/16	309
200	4 11/32	4 1/8	7 27/32	3 15/16	6 7/32	18 15/16	11 1/32	29 7/8	18 1/2	18 31/32	1 31/32	8 1/16	452
250	4 31/32	4 23/32	8 15/16	4 11/32	7 1/16	21 11/32	11 13/16	33 13/16	20 2/16	20 7/8	2 3/8	9 7/16	582
300	5 5/16	5 9/32	9 21/32	4 13/16	7 11/16	23 21/32	13 25/32	37 9/32	22 5/8	24 13/32	3 3/4	10 7/16	794
400	6 5/16	6 9/16	11 17/32	5 23/32	9 3/32	22 11/16	14 9/16	38 29/32	26 9/16	27 5/32	3 5/32	12 19/32	1279
500	6 11/16	7 3/32	12 29/32	6 5/16	10 11/32	26 13/16	17 23/32	44 17/32	29 7/16	31 3/32	3 17/32	13 11/32	1720
600	7 15/32	7 7/8	13 11/16	6 11/16	11 3/8	29 3/16	19 9/32	48 19/32	31 21/32	34 1/16	3 15/16	14 9/16	2161
700	7 7/8	8 15/32	15 7/16	7 15/32	12 13/32	29 9/16	21 1/4	50 9/16	34 19/32	35 15/32	3 15/16	15 3/4	2998
800	8 19/32	9 1/16	16 17/32	7 7/8	13 15/32	33 1/2	21 13/16	56 5/32	37 3/32	37 9/32	4 11/32	16 17/32	3153
900	9 17/32	10 1/32	18 11/32	8 21/32	14 1/2	33 1/2	22 27/32	58 19/32	40 9/32	40 9/32	4 23/32	17 5/16	3638
1000	10 1/4	10 5/8	19 9/32	9 7/16	15 23/32	33 1/2	24 3/16	60 5/16	43 7/16	43 19/32	4 23/32	18 1/8	6548
1250	11 7/32	11 13/16	20 3/32	10 1/4	17 25/32	36 21/32	25 19/32	65 19/32	48 5/16	46 17/32	5 29/32	20 7/8	8157
1550	11 7/32	12 19/32	21 21/32	11 1/32	19 1/32	37 13/32	26 25/32	67 5/16	51 3/16	49 11/32	5 29/32	22 1/16	8818



Green Pin® Heavy Duty Shackles

Bow Shackles with Safety Bolt

- Material** : Bow and pin alloy steel, Grade 8 quenched and tempered
- Safety Factor** : MBL equals 5 x WLL
- Finish** : Shackle bow painted silver, pin painted green (120 tons shackle is hot dipped galvanized)

Certification : At no extra charges this product can be supplied with a works certificate, certification of basic raw material, manufacturer test certificate, EC Declaration of Conformity and all shackles starting from 150 tons are supplied with a Lloyd's Register of Shipping Certificate on proof load.

Note : +5% forging tolerance on inside width and length

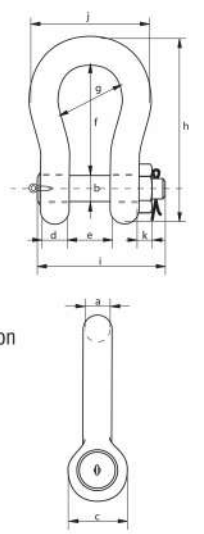

working load limit	diameter bow	diameter pin	diameter eye	width eye	width inside	length inside	width bow	length bow	length bolt	width	thickness nut	weight each
tons	a	b	c	d	e	f	g	h	i	j	k	kg
120	95	95	215	89	144	381	238	667	440	416	50	110
150	105	108	245	100	165	400	275	702	490	485	60	160
200	120	130	288	110	175	500	290	854	520	530	60	235
250	130	140	308	115	200	540	305	921	560	565	65	285
300	140	150	335	120	200	600	305	1018	575	585	70	340
400	170	175	387	160	225	650	325	1137	690	665	70	560
500	180	185	410	160	250	700	350	1213	710	710	70	685
600	200	205	458	185	275	700	375	1267	810	775	70	880
700	210	215	468	200	300	700	400	1287	850	820	70	980
800	210	220	478	200	300	700	400	1294	870	820	70	1100
900	220	230	500	210	320	700	420	1320	920	860	70	1280
1000	240	240	530	210	340	700	420	1360	940	900	70	1460
1250	260	270	600	225	360	700	450	1430	1020	970	70	1990
1500	280	290	640	225	360	700	450	1480	1060	1010	70	2400

In inch

working load limit	diameter bow	diameter pin	diameter eye	width eye	width inside	length inside	width bow	length bow	length bolt	width	thickness nut	weight each
tons	a	b	c	d	e	f	g	h	i	j	k	lbs
120	3 3/4	3 3/4	8 1/2	3 17/32	5 11/16	15	9 11/32	26 9/32	17 5/16	16 3/8	2	243
150	4	4 1/8	9 5/8	3 15/16	6 17/32	15 3/4	10 13/16	27 5/8	19 9/32	19 1/8	2 3/8	353
200	4 3/4	5 1/8	11 11/32	4 5/16	6 29/32	19 11/16	11 7/16	33 5/8	20 1/2	20 7/8	2 3/8	518
250	4 7/8	5 1/4	12 1/2	4 17/32	7 7/8	21 9/32	12	36 9/32	22 1/2	22 1/4	2 9/16	628
300	5 5/16	5 7/8	13 3/16	4 23/32	7 7/8	23 5/8	12	40	22 5/8	23	2 3/4	750
400	6 1/2	6 7/8	15 1/4	6 5/16	8 7/8	25 19/32	12 25/32	44 3/4	27 5/32	26 1/4	2 3/4	1235
500	6 7/8	7 1/4	16 5/32	6 5/16	9 13/16	27 1/2	13 25/32	47 3/4	28	28	2 3/4	1510
600	7 5/8	8 1/16	18	7 9/32	10 13/16	27 1/2	14 3/4	49 7/8	31 7/8	30 1/2	2 3/4	1940
700	8 1/16	8 1/2	18 7/16	7 7/8	11 13/16	27 1/2	15 3/4	50 11/16	33 1/8	32 3/8	2 3/4	2161
800	8 1/8	8 5/8	18 13/16	7 7/8	11 13/16	27 1/2	15 3/4	51	34 1/4	32 3/8	2 3/4	2425
900	8 5/8	9 1/16	19 11/16	8 9/32	12 19/32	27 1/2	16 9/16	52	36 1/4	33 7/8	2 3/4	2822
1000	9 1/16	9 7/16	20 7/8	8 9/32	13 3/8	27 1/2	16 9/16	53 9/16	37	35 1/8	2 3/4	3219
1250	10 1/4	10 5/8	23 5/8	8 7/8	14 5/32	27 1/2	17 23/32	56 5/16	40 1/4	38 1/2	2 3/4	4387
1500	11	11 7/16	25 3/16	8 7/8	14 5/32	27 1/2	17 23/32	58 5/16	41 3/4	39 3/4	2 3/4	5291

FLAT POLYESTER WEBBING SLINGS

- Flat Webbing Slings are made with high tenacity polyester webbing
- Slings are manufactured either to EN 1492-2:2000 with Safety factor 7:1
- We offer slings in MM system (i.e. 30mm, 60mm, 900mm etc.) and also in inch system (i.e. 1" 2" 3")



Color Code	Width in Inches	M=1		M=.8		M=2		M=1.4		M=1	
		Straight Lift		Choker Lift		Basket/U-Lift		At angle Beta 0-45		At angle Beta 45-60	
		1-PLY	2-PLY	1-PLY	2-PLY	1-PLY	2-PLY	1-PLY	2-PLY	1-PLY	2-PLY
Violet	1	500	1000	400	800	1000	2000	700	1400	500	1000
Green	2	1000	2000	800	1600	2000	3000	1400	2800	1000	2000
Yellow	3	1500	3000	1200	2400	3000	6000	2100	4200	1500	3000
Grey	4	2000	4000	1600	3200	4000	8000	2800	5600	2000	4000
Red	5	2500	5000	2000	4000	5000	10000	3500	7000	2500	5000
Brown	6	3000	6000	2400	4800	6000	12000	4200	8400	3000	6000
Blue	8	4000	8000	3200	6400	8000	16000	5600	11200	4000	8000
Orange	10	5000	10000	4000	8000	10000	20000	7000	14000	5000	10000
Orange	12	6000	12000	4800	9600	12000	24000	8400	16800	6000	12000

Color Code	Width in Inches	M=1		M=.8		M=2		M=1.4		M=1	
		Straight Lift		Choker Lift		Basket/U-Lift		At angle Beta 0-45		At angle Beta 45-60	
		3-PLY	4-PLY	3-PLY	4-PLY	3-PLY	4-PLY	3-PLY	4-PLY	3-PLY	4-PLY
Violet	1	1500	2000	1200	1600	3000	4000	2100	2800	1500	2000
Green	2	3000	4000	2400	3200	6000	8000	4200	5600	3000	4000
Yellow	3	4500	6000	3600	4800	9000	12000	6300	8400	4500	6000
Grey	4	6000	8000	4800	6400	12000	16000	8400	11200	6000	8000
Red	5	7500	10000	6000	8000	15000	20000	10500	14200	7500	10000
Brown	6	9000	12000	7200	9600	18000	24000	12600	16800	9000	12000
Blue	8	12000	16000	9600	12800	24000	32000	16800	22400	12000	16000
Orange	10	15000	20000	12000	16000	30000	40000	21000	28000	15000	20000
Orange	12	18000	24000	14400	19200	36000	48000	25200	33600	18000	24000

I	o	U	∩	∪
Straight Pull	Choke Lift	Basket Lift 0.7°	Basket Lift 0 to 45°	Basket Lift 45 to 60°

ENDLESS ROUND SLINGS

- Endless Round Slings are made with high tenacity polyester webbing.
- Round Slings are manufactured either to EN 1492-2:2000 with Safety factor 7:1.
- Color coded and striped for WLL (Working Load Limit) Identification.
- We offer slings in MM system (i.e. 30mm, 60mm, 900mm etc.) and also in inch system (i.e. 1" 2" 3"etc)



APPROX. DIA	COLOUR CODE	WLL kg with one Round Endless Sling								WLL kg with two Round Endless Sling	
		Straight Lift	Choke Hitch	Basket Hitch			Straight Inclination		Choke Inclination		
				up to 7°	7° - 45°	45° - 60°	7° - 45°	45° - 60°	7° - 45°	45° - 60°	
	Mode Factor	M=1.0	M=0.8	M=2	M=1.4	M=1.0	M=1.4	M=1.0	M=1.12	M=0.8	
18	Violet	1000	800	2000	1400	1000	1400	1000	1120	800	
20	Green	2000	1600	4000	2800	2000	2800	2000	2240	1600	
22	Yellow	3000	2400	6000	4200	3000	4200	3000	3360	2400	
25	Grey	4000	3200	8000	5600	4000	5600	4000	4480	3200	
28	Red	5000	4000	10000	7000	5000	7000	5000	5600	4000	
32	Brown	6000	4800	12000	8400	6000	8400	6000	6720	4800	
38	Blue	8000	6400	16000	11200	8000	11200	8000	8960	6400	
46	Orange	10000	8000	20000	14000	10000	14000	10000	11200	8000	
58	Orange	12000	9600	24000	16800	12000	16800	12000	13440	9600	
70	Orange	15000	12000	30000	21000	15000	21000	15000	16800	12000	
78	Orange	20000	16000	40000	28000	20000	28000	20000	22400	16000	
90	Orange	25000	20000	50000	35000	25000	35000	25000	28000	20000	
100	Orange	30000	24000	60000	42000	30000	42000	30000	33600	24000	
115	Orange	36000	28800	72000	50400	36000	50400	36000	40320	28800	
180	Orange	50000	40000	100000	70000	50000	70000	50000	56000	40000	
200	Orange	75000	60000	150000	105000	75000	105000	75000	84000	60000	
250	Orange	100000	80000	200000	140000	100000	140000	100000	112000	80000	

STEEL WIRE ROPE

Construction: 19 x 7 class Wire Rope

- This wire rope construction is available in both galvanised and un galvanised finish in ordinary lay and lang's lay.
- Depending upon your requirement for higher breaking load or better wear characteristics, these wire ropes are available in different finishes and lubrications as well as being available with plastic impregnated or in compacted constructions.

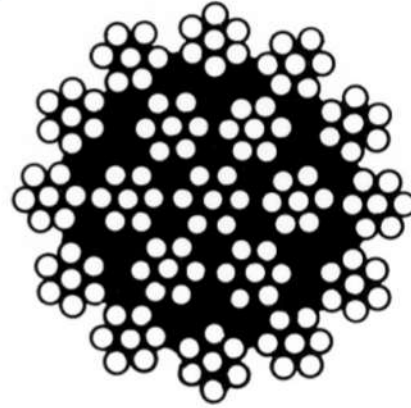

Applications

- Offshore crane rope
- Deck crane rope
- Pillar crane rope
- Whip hoist rope
- Main hoist rope
- Crane rope

• Available brands: DSR – South Korea, Brunton wolf – UAE, Bharat wire rope – India

Nominal Dia.		Minimum Breaking Load (Metric Ton)			Approx Weight
		180 Kg/mm	200 Kg/mm	220 Kg/mm	
mm	inch	1770 N/mm	1960 N/mm	2160 N/mm	Kg/m
9.53	3/8	7.3	7.9	8.8	0.44
10		8.0	8.7	9.7	0.48
11.2	7/16	10.1	10.9	12.1	0.60
12		11.6	12.6	13.9	0.69
12.7	1/2	13.0	14.1	15.6	0.78
13		13.6	14.7	16.4	0.81
14		15.8	17.1	19.0	0.94
14.3	9/16	16.5	17.8	19.8	0.98
15		18.1	19.6	21.8	1.08
16	5/8	20.6	22.3	24.8	1.23
17.5	11/16	24.6	26.7	29.6	1.47
18		26.1	28.3	31.4	1.56
19	3/4	29.1	31.5	34.9	1.74
20		32.2	34.9	38.7	1.93
21	13/16	35.5	38.5	42.7	2.12
22		38.9	42.2	46.8	2.33
22.2	7/8	39.7	43.1	47.8	2.38
24	15/16	46.4	50.2	55.8	2.77
25		50.3	54.5	60.5	3.01
25.4	1	51.9	56.3	62.4	3.11
26		54.4	58.9	65.4	3.25
28		63.1	68.4		3.77
28.6	1-1/8	65.8	71.3		3.94
30	1-3/16	72.4	78.5		4.33
31.8	1-1/4	81.4	88.2		4.87
32		82.4	89.3		4.93

STEEL WIRE ROPE

Construction: 35 x 7 class wire rope

- 35X7 is available in both galvanised and un-galvanised finish with lang's lay in 2160 grade.
- Depending upon your requirement for higher breaking load or better wear characteristics, these wire ropes are available in different finishes and lubrications as well as being available with plastic impregnated or in compacted constructions.

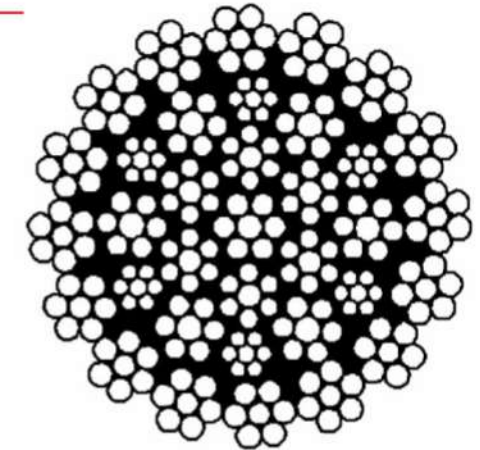

Applications

- Offshore crane rope
- Deck crane rope
- Pillar crane rope
- Whip hoist rope
- Main hoist rope
- Crane rope

• Available brands: DSR – South Korea, Brunton wolf – UAE.

POWERFLEX 35, 35L

Nominal Dia.		Minimum Breaking Load (Metric Ton)		Approx Weight
		200 Kg/mm	220 Kg/mm	
mm	inch	1960 N/mm	2160 N/mm	Kg/m
14		18.3	19.6	1.00
14.3	9/16	19.1	20.4	1.04
15		21.0	22.5	1.15
16	5/8	23.9	25.6	1.31
17	11/16	28.9	30.6	1.56
18		30.3	32.4	1.65
19	3/4	33.7	36.1	1.84
20		37.3	40.0	2.04
21	13/16	41.2	44.1	2.25
22		45.2	48.4	2.47
23	7/8	46.1	49.4	2.52
24	15/16	53.8	57.6	2.94
25		58.4	62.5	3.19
25.4	1	60.2	64.5	3.29
26		63.1	67.6	3.45
28		73.2	78.4	4.00
28.6	1-1/8	76.4	81.8	4.17
30	1-3/16	84.0	90.0	4.59
31.8	1-1/4	94.4	101.1	5.16
32		95.6	102.4	5.22
34		107.9	115.6	5.90
35	1-3/8	114.4	122.5	6.25
36		121.0	129.6	6.61
38		134.8	144.4	7.37

STEEL WIRE ROPE

Construction: 6 x 36 class wire rope

6x36 is a flexible general engineering wire rope readily available in galvanised and un-galvanised. The wire rope has an equal lay construction and achieves a superior breaking load to the 6x19 construction range. The construction has been designed to give a flexible rope with a good fatigue life. A 6x36 wire rope is available with either FC (fibre core) or IWRC (independent wire rope core) and is used for a wide range of applications, examples of which are shown below:

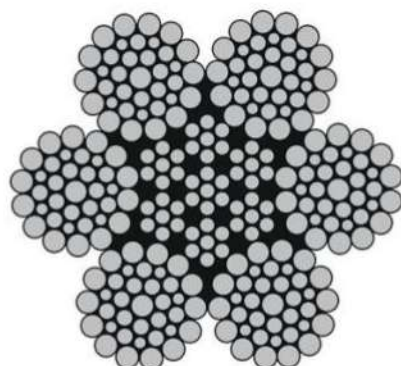

6x37 Class Rope

Nominal Dia.		Minimum Breaking Load (Metric Ton)					Approx Weight	
mm	inch	180 Kg/mm		200 Kg/mm		220 Kg/mm		Kg/m
		1770 N/mm		1960 N/mm		2160 N/mm		
		FC	IWRC	FC	IWRC	IWRC	FC	IWRC
11.2	7/16	8.9	9.9	9.3	10.7		0.53	0.58
12		10.2	11.4	10.7	12.3		0.60	0.66
12.7	1/2	11.4	12.7	12.0	13.8		0.68	0.74
13		12.0	13.4	12.5	14.4		0.71	0.77
14		13.9	15.5	14.6	16.7	17.5	0.82	0.90
14.3	9/16	14.5	16.2	15.2	17.4	18.2	0.86	0.94
15		16.0	17.8	16.7	19.2	20.1	0.94	1.03
16	5/8	18.2	20.2	19.0	21.8	22.8	1.07	1.17
17.5	11/16	21.7	24.2	22.7	26.1	27.3	1.28	1.40
18		23.0	25.6	24.1	27.6	28.9	1.36	1.49
19	3/4	25.6	28.5	26.8	30.8	32.2	1.51	1.65
20	13/16	28.4	31.6	29.7	34.1	35.7	1.67	1.83
21		31.3	34.8	32.7	37.6	39.3	1.85	2.02
22	7/8	34.3	38.2	35.9	41.3	43.1	2.03	2.22
22.2	15/16	35.0	39.0	36.7	42.1	44.0	2.07	2.26
24		40.9	45.5	42.8	49.1	51.3	2.41	2.64
25		44.3	49.4	46.4	53.3	55.7	2.62	2.86
25.4	1	45.8	51.0	47.9	55.0	57.5	2.70	2.96
26		48.0	53.4	50.2	57.7	60.3	2.83	3.10
28		55.6	61.9	58.2	66.9	69.9	3.28	3.59
28.6	1-1/8	58.0	64.6	60.7	69.8	72.9	3.42	3.75
30	1-3/16	63.9	71.1	66.8	76.8	80.2	3.77	4.13
31.5	1-1/4	70.4	78.4	73.7	84.6	88.4	4.15	4.55
32		72.7	80.9	76.0	87.3	91.3	4.29	4.69
34		82.0	91.3	85.8	98.6	103.0	4.84	5.30
35	1-3/8	86.9	96.8	90.9	104.5	109.2	5.13	5.62
36		92.0	102.4	96.2	110.5	115.5	5.42	5.94
38		102.5	114.1	107.2	123.2	128.7	6.04	6.62
38.1	1-1/2	103.0	114.7	107.8	123.8	129.4	6.08	6.65
40		113.5	126.4	118.8	136.5		6.70	7.33
42		125.2	139.4	131.0	150.5		7.38	8.09
44		137.4	152.9	143.7	165.1		8.10	8.87
44.5	1-3/4	140.2	156.1	146.7	168.5		8.27	9.06
46		150.1	167.2	157.1	180.5		8.86	9.70
48		163.5	182.0				9.64	10.56
50		177.4	197.5				10.46	11.46
50.8	2	183.1	203.9				10.80	11.83
52		191.8	213.6				11.32	12.93

Applications

- Holding and closing ropes for grab cranes
- General engineering applications
- Wire rope slings
- Crane ropes
- Winch ropes
- Hoist rope
- Wire rope rigging applications
- Lifeboat falls
- Mooring ropes
- Luffing ropes
- Tow ropes

Available brands: DSR – South Korea, Brunton wolf – UAE, Bharat wire rope – India

STEEL WIRE ROPE SLINGS

- Types: Soft eyes & Thimble eyes mechanically spliced with aluminium ferrule and Soft eyes & Thimble eyes Flemish spliced with steel ferrules.
- Conform to BS EN 13414-1:2003
- Fully certified and individually stamped for full traceability.

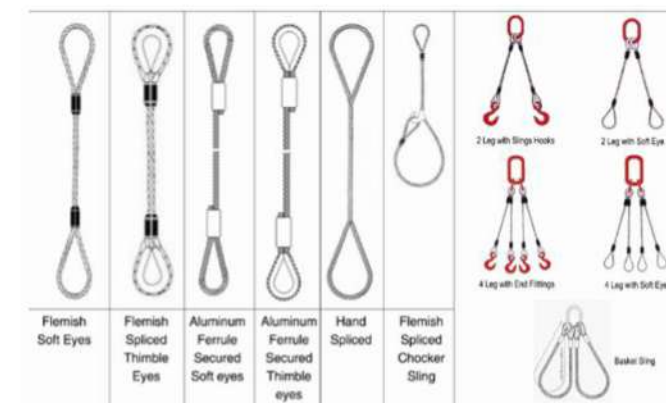

Angle to the vertical	Single leg sling		Two leg sling		Three and Four leg sling	
	0 Deg	90°	0 -45 Deg	45-60 Deg	0-45 Deg	45-60 Deg
Nominal Rope Dia (mm)	Working Load Limits (Tonnes)					
8	(5/16")	0.82	1.15	0.82	1.72	1.23
9		1.00	1.40	1.00	2.10	1.50
10	(3/8")	1.30	1.80	1.30	2.73	1.95
11		1.50	2.10	1.50	3.15	2.25
12		1.80	2.50	1.80	3.80	2.70
13	(1/2")	2.10	2.90	2.10	4.40	3.15
14	(9/16")	2.50	3.50	2.50	5.25	3.75
16	(5/8")	3.30	4.60	3.30	6.90	4.95
18		4.10	5.70	4.10	8.60	6.15
19	(3/4")	4.60	6.40	4.60	9.65	6.90
20		5.10	7.10	5.10	10.70	7.65
22	(7/8")	6.20	8.70	6.20	13.00	9.30
24		7.40	10.30	7.40	15.50	11.10
26	(1")	8.60	12.00	8.60	18.05	12.90
28	(1-1/8")	10.00	14.00	10.00	21.00	15.00
32	(1-1/4")	13.10	18.30	13.00	27.50	19.65
36	(1-3/8")	16.60	23.20	16.60	34.85	24.90
38	(1-1/2")	18.50	25.90	18.50	38.85	27.75
40		20.60	28.80	20.60	43.25	30.90
42	(1-5/8")	22.60	31.60	22.60	47.45	33.90
44	(1-3/4")	24.80	34.70	24.80	52.10	37.20
48	(1-7/8")	29.50	41.40	29.50	61.95	44.25
52	(2")	34.80	48.70	34.80	73.10	52.20
56	(2-1/4")	40.20	56.30	40.20	84.40	60.30
60		46.20	64.70	46.20	97.00	69.30
64	(2-1/2")	54.80	76.70	54.80	115.10	82.20
71	(2-3/4")	66.60	93.20	66.60	139.85	99.90
76	(3")	76.50	107.10	76.50	160.65	114.75
83	(3-1/4")	89.60	125.50	89.60	188.20	134.46
89	(3-1/2")	101.00	141.40	101.00	212.10	151.50
103	(4")	129.00	180.60	129.00	270.90	193.50

CABLE LAID GROMMET SLINGS

- Made from one continuous length of strand or rope laid around itself as a core to make a round and endless 7-strand sling. Short centred slings for heavy loads, large dredge bucket slings and as alternatives for other sling types. We are able to manufacture large diameter cable laid grommet slings that exceed current EN 13414-3 standards
- All cable laid grommet slings are load tested and third part witness to test can be arranged if required
- Wire rope Grommets can be made up to 1000 Tons capacity
- Very long lengths can be made up
- Ideal for heavy lifts

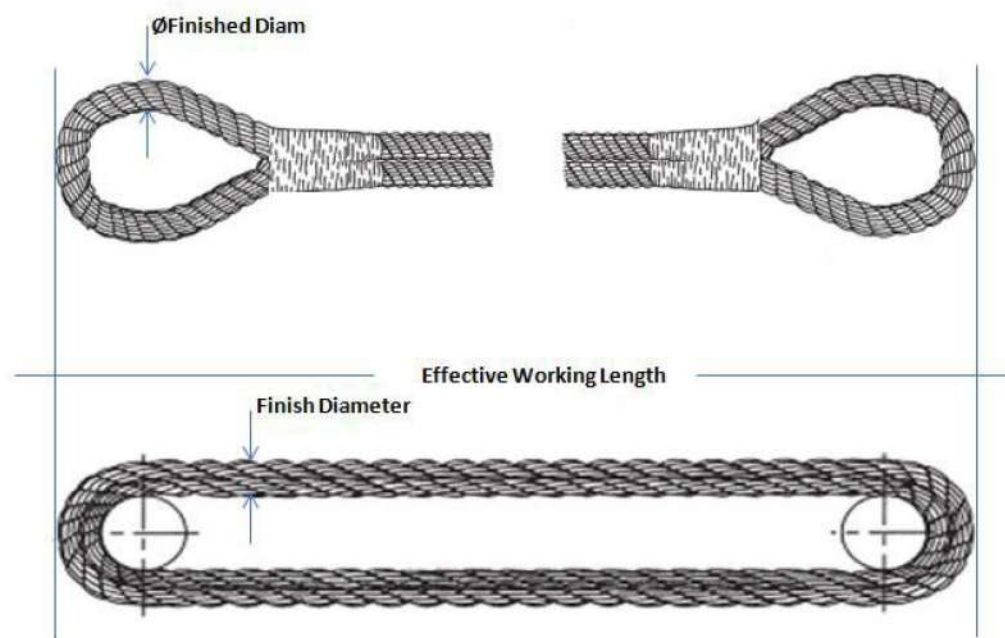

MANILA ROPE – 3 STRAND

Manila rope, sometimes referred to as “hemp rope”, is manufactured from the strongest natural fibers available of the abaca plant grown in the Philippines. Manila rope provides high strength with very good resistance to abrasion and low stretch.

This versatile rope is used widely in many different applications and industries. Some of the common industries include:

- Agriculture
- Industrial
- Construction
- Marine

Manila rope is also widely used in different applications such as decorative rope, dock railings, bridge rails, outside rope fencing, landscape rope, climbing rope, exercise rope, and tug-o-war rope

We stock Grade No. 3 Manila Rope, 3-Strand, with diameters of 1/4", 5/16", 3/8", 1/2", 5/8", 3/4", 1", 1-1/8", 1-1/4", 1-1/2", minimum of 5% oil content, minimum breaking strength of new rope and actual breaking strength is provided on request



POLYPROPYLENE ROPE – 3 STRAND & 8 STRAND

Properties:

- High Breaking Strength
- Light Weight
- Controlled Elongation
- Unaffected by Acids & Alkalies
- Negligible Water absorption
- Abrasion Resistant
- U.V. Stabilized & Long lasting

Applications:

- In Fishery Industry
- For Submersible Pumps
- For Marine Purposes
- For Construction
- In Agriculture
- In Transportation

In Transportation

- Spliced with eyes
- Special lengths
- Reworked components – Metal, plastic (Eye sockets, hooks, carabiners etc)



High Strength Polypropylene Rope (Danline)		
Dia (mm)	Weight per coil of 100 Mtrs (KG)	Minimum Breaking Strength (KGF)
4	0.72	320
6	1.63	690
8	2.90	1200
10	4.53	1800
12	6.52	2600
14	8.88	3500
16	11.60	4400
18	14.70	5600
20	18.10	6800
22	21.90	8100
24	26.10	9500
26	30.60	10900
28	35.50	12500
30	40.80	14300
32	46.40	16000
36	58.70	19800

High Strength Polypropylene Rope (Danline)			
Dia (mm)	Circ (inches)	Weight per coil of 100 Mtrs (KG)	Minimum Breaking Strength (KGF)
36	4.5	59	22800
40	5	72	27900
44	5.5	88	33300
48	6	104	39300
52	6.5	122	45700
56	7	142	52400
60	7.5	163	59400
64	8	186	67000
72	9	235	83600
80	10	290	101400
88	11	351	121300
96	12	417	142700
104	13	490	165100
112	14	568	191600
120	15	652	217100

NYLON ROPE – 3 STRAND

Nylon Rope has twice the strength of Manila rope. It has high elongation (under load) when compared to other synthetic ropes. Nylon has high energy absorption under shock and good abrasion resistance. When combined, these characteristics make nylon rope the best in handling compared to other synthetics. It is utilized extensively in marine use such as mooring lines, towing slings, commercial fishing, utility rope, leisure boating, and sailing etc.



- **Fiber Content:** Nylon fiber
- **Specific gravity:** 1.14
- **Melting Point:** 220°C
- **Elongation at break:** 45% (8S/T), 30% (12S/T)
- **Water absorption:** 2 ~ 5%

Dia.		Circ.		Weight			Breaking Strength	
mm	Inch	Inch	KGS/100M	LBS/100FT	LBS/100FM	Kg	kN	
4	5/32	1/2	1.05	0.71	4.23	360	3.53	
5	3/16	5/8	1.56	1.05	6.29	570	5.60	
6	1/4	3/4	2.25	1.51	9.07	760	7.46	
7	9/32	7/8	3.1	2.08	12.50	1,050	10.30	
8	5/16	1	4.0	2.69	16.13	1,390	13.65	
9	3/8	1-1/8	5.0	3.36	20.16	1,750	17.20	
10	13/32	1-1/4	6.2	4.17	25.00	2,130	20.90	
11	7/16	1-3/8	7.5	5.04	30.24	2,600	25.50	
12	15/32	1-1/2	8.9	5.98	35.88	3,040	29.80	
13	1/2	1-5/8	10.5	7.06	42.33	3,570	35.00	
14	9/16	1-3/4	12.2	8.20	49.19	4,180	41.00	
16	5/8	2	15.8	10.62	63.70	5,380	52.80	
18	23/32	2-1/4	20.0	13.44	80.64	6,880	67.50	
19	3/4	2-3/8	22.1	14.85	89.10	7,650	75.10	
20	13/16	2-1/2	24.5	16.46	98.78	8,450	82.90	
22	7/8	2-3/4	30.0	20.16	120.96	10,400	102.00	
24	15/16	3	35.5	23.86	143.13	12,300	120.70	
25	1	3-1/8	38.8	26.07	156.44	13,400	131.50	
26	1-1/32	3-1/4	42.0	28.22	169.37	14,500	142.20	
28	1-1/8	3-1/2	48.5	32.59	195.54	16,200	159.00	
30	1-3/16	3-3/4	55.5	37.29	223.77	18,300	179.50	
32	1-1/4	4	63.0	42.98	254.01	20,600	202.00	
34	1-11/32	4-1/4	71.4	47.98	287.87	23,200	227.10	
36	1-7/16	4-1/2	80.0	53.76	322.55	25,700	252.10	

Dia.		Circ.		Weight			Breaking Strength	
mm	Inch	Inch	KGS/100M	LBS/100FT	LBS/100FM	Kg	kN	
38	1-1/2	4-3/4	89.3	60.01	360.04	28,200	276.60	
40	1-19/32	5	99.0	66.53	399.15	31,000	304.10	
42	1-21/32	5-1/4	109.0	73.25	439.47	33,800	331.60	
44	1-3/4	5-1/2	120.0	80.64	483.82	37,000	363.00	
45	1-13/16	5-5/8	124.8	83.86	503.17	37,800	370.80	
48	1-7/8	6	142.0	95.42	572.52	43,000	421.80	
50	2	6-1/4	153.5	103.15	618.89	46,300	454.20	
52	2-1/16	6-1/2	166.0	111.55	669.28	50,000	490.50	
55	2-5/32	6-7/8	186.2	125.12	750.73	55,000	539.50	
56	2-1/4	7	193.0	129.96	778.14	57,000	559.20	
60	2-3/8	7-1/2	221.0	148.51	891.04	64,500	632.70	
64	2-1/2	8	252.0	169.34	1,016.02	73,000	716.10	
65	2-9/16	8-1/16	260.0	174.71	1,048.28	75,000	735.70	
70	2-3/4	8-11/16	302.0	202.94	1,217.61	86,000	843.60	
72	2-7/8	9	319.0	214.36	1,286.16	91,000	892.70	
75	3	9-1/4	346.0	232.50	1,395.01	98,700	968.20	
80	3-5/32	10	394.0	264.76	1,588.54	111,500	1,093.80	
85	3-3/8	10-1/2	445.0	299.03	1,794.17	126,000	1,236.00	
88	3-7/16	11	477.0	320.53	1,923.19	135,000	1,324.30	
90	3-9/16	11-1/8	499.0	335.31	2,011.89	139,000	1,363.60	
95	3-3/16	11-3/4	556.0	373.68	2,241.70	154,000	1,510.70	
96	3-13/16	12	568.0	381.68	2,290.08	158,000	1,550.00	
100	3-15/16	12-3/8	616.0	413.94	2,483.61	170,000	1,667.70	

MANUAL HOIST



Hand Chain Block - LMCB

Load from 0.5 to 30 Ton

LMCB is a compact, high performance

Hand chain block, tested according to applicable Standards.

TECHNICAL FEATURES

- Machined chain sprocket and gears provide smoother more efficient operation.
- 3 meters/6 meters standard lift, Non – standard lift also available.
- High strength Gr.80 alloy steel load chain with black finish
- LMCB's compact design offers safety together with reduced weight, ideal for
- Construction and maintenance applications
- Alloy steel components have specific heat treatment which avoids sudden break
- Steel casing solidly protects chain sprockets, gear case and hand wheel cover
- LMCB comes with automatic double pawl breaking system
- High resistance industrial powder coating meets ROHS requirement
- 1500 cycles life test meets EN 13157, ANSI B30 16, AS1418 standards
- Factor of safety- 4:1
- Proof load – 1.5 WLL

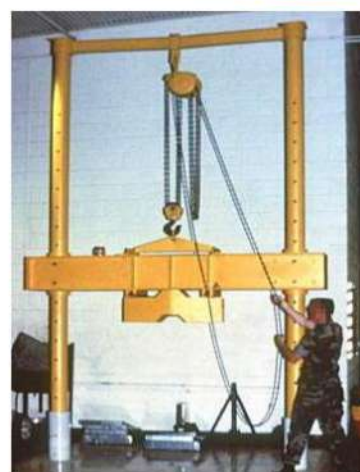

Hand Chain Block - LMCB

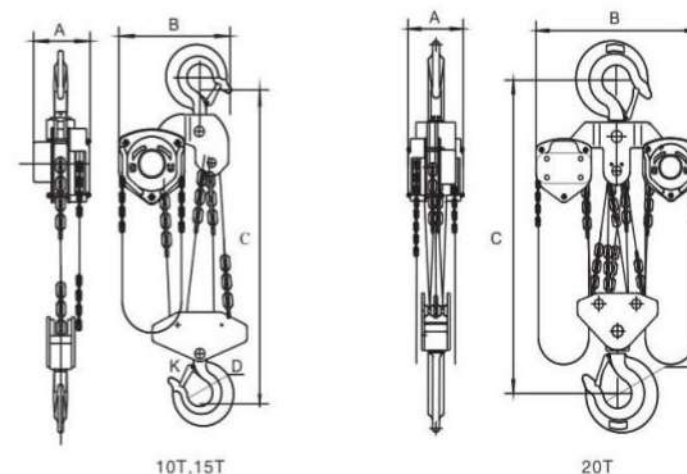
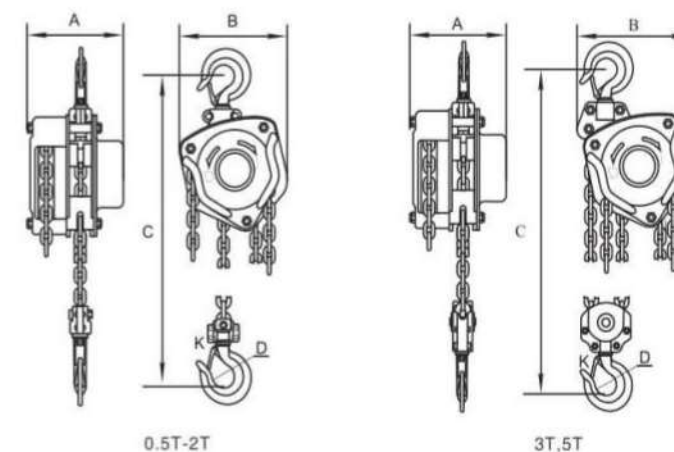

CHAIN BLOCK SPECIFICATIONS

Model No	Capacity (Kg)	Standard Lift(m)	Running Test Load (KN)	Effort Required to Lift (N)	Dia of Load Chain (mm)	No of Falls	Dimension					Net Weight (KG)	Extra Weight Per Meter of extra lift (KG)
							A	B	C	D	K		
LMCB-1	1	2.5	15	300	6	1	152	157	355	38	27	11	1.6
LMCB-1.5	1.5	2.5	22.5	350	8	1	155	180	375	48	36	14.5	2.3
LMCB-2	2	3	30	310	8	1	185	207	430	48	36	17.5	2.3
LMCB-3	3	3	45	350	8	2	152	207	500	50	38	20.5	3.2
LMCB-5	5	3	75	415	10	2	189	267	680	57	48	39.5	5.3
LMCB-10	10	3	150	415	10	4	189	380	750	80	51	65	9.7
LMCB-15	15	3	225	420	10	6	194	400	880	85	58	102	14
LMCB-20	20	3	300	410*2	10	8	224	440	940	106	70	156	19.3
LMCB-30	30	3	450	410*2	10	12	274	649	1100	120	80	246	28.3

Lever Hoist- LMLH

- Load from 0.25 to 9 Tons
- The LMLH manual lever hoist is a compact unit
- For lifting, pulling and sliding. Especially suitable for industrial use

TECHNICAL FEATURES

- Choice of rust, compact, lightweight, easy handling units
- Standard chain lengths 1.5 mtrs and Non-standard chain length available on request.
- LMLH can be used in any position, simply switch the lever to make the hoist easier to handle.
- LMLH comes with asbestos Free Friction Disc
- LMLH comes with Automatic double pawl braking system
- Reinforced casing effectively protects mechanisms
- High resistance industrial powder coating meets ROHS requirement
- Extra safe, light weight and low maintenance
- High strength GR 80 alloy load chain with black finish
- 1500 cycle life test meets ANSI B30-21, AS1418 standards
- Factor of safety-4:1
- Proof Load- 1.5WLL



Lever Hoist- LMLH

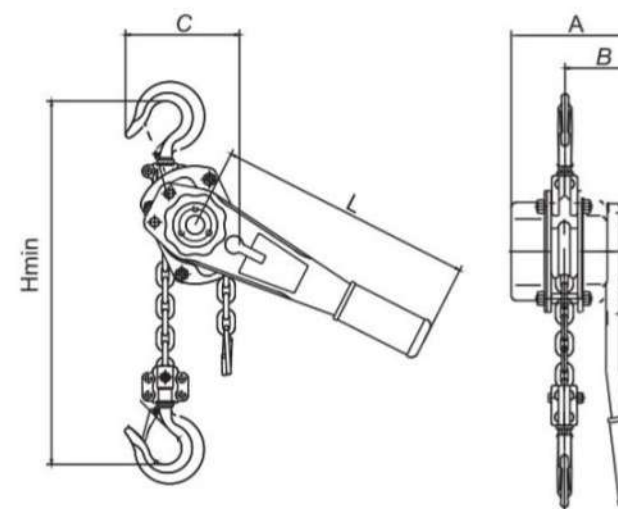

LEVER HOIST SPECIFICATIONS

Model No	Capacity (Kg)	Standard Lift(m)	Running Test Load (KN)	Effort Required to Lift (N)	Dia of Load Chain (mm)	No of Falls	Dimension					Net Weight	Extra Weight Per Meter of extra lift (KG)
							A	B	C	H	L		
LMLH-0.25	0.25	1	3.75	250	4	1	92	72	85	230	160	1.8	0.41
LMLCB-0.5	0.5	1.5	7.5	340	5	1	105	78	80	260	300	4	0.52
LMLH-0.75	0.75	1.5	11.2	140	6	1	153	86	130	295	315	7.5	0.8
LMLH-01	1	1.5	15	185	6	1	153	96	130	295	315	7.5	0.8
LMLH-1.5	1.5	1.5	22.5	230	7.1	1	166	100	150	335	365	9.5	1.1
LMLH-02	2	1.5	30	251	8	1	175	105	160	385	368	15.5	1.4
LMLH-03	3	1.5	45	385	10	1	195	112	202	450	365	16.5	2.2
LMLH-06	6	1.5	75	385	10	2	195	112	242	550	365	27	4.4
LMLH-09	9	1.5	135	390	10	3	195	112	312	660	365	40	6.6

WIRE ROPE PULLER

Model: LMRW

Loads from 0.8 to 5.4 Tons

Wire rope pullers are portable manual hoist used with wire rope. They can be used to lift, pull and position loads over great distances depending on the wire rope length. They are suitable for use in numerous configurations and the ideal solution for use in professional applications. They are operated by a simple lever option and the load capacity of the wire rope puller system can be increased by using

TECHNICAL FEATURES

- Low weight – Quick installation
- Standard cable length – 20 Mtrs, Non standard
- Cable length also available
- Manageable, Robust and Powerful
- Increase load capacity with deflection sheaves
- Overload protection
- Precise load placement within millimeters

NO WHEELS OR GEARS REQUIRED

- Two jaws alternately pull the wire rope and the load in the required direction, just like pulling on a rope with both hands
- The jaws are self-clamping, providing immediate and gradual safety
- The heavier the load, the tighter they clamp

MULTIFUNCTION

- Work can be performed in any position; horizontal, vertical or at an angle
- There is no limit to the length of wire rope

SAFETY AND RELIABLE

- Constant control of the load during lifting and lowering with accuracy to within one millimeter
- When stationary, the load is automatically distributed between the two jaw units
- Overload safety device

INCREASED CAPACITY

- Using the sheave block technique, the capacity of the Wire rope puller can be increased by a factor of 2, 3, 4 or more

WIRE ROPE PULLER

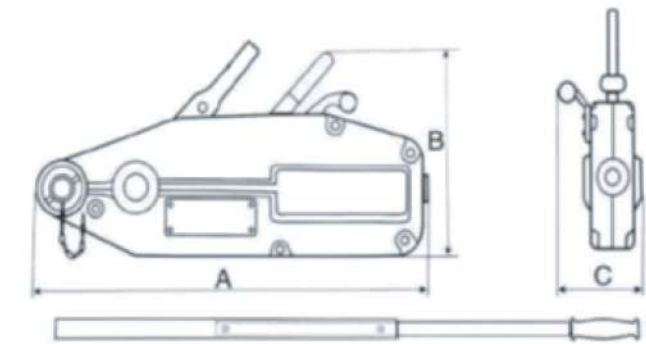
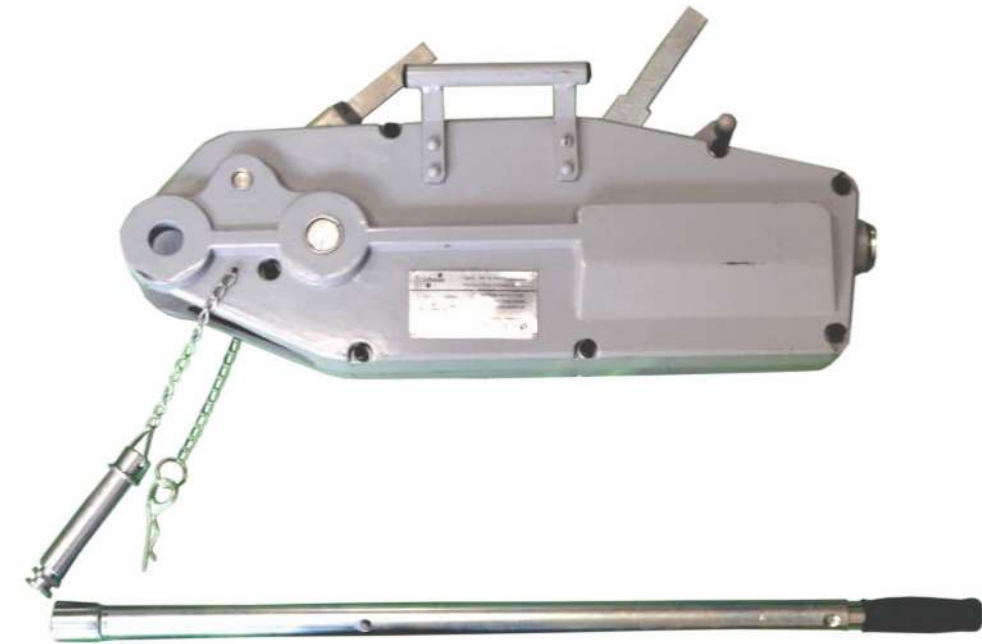

WIRE ROPE PULLER SPECIFICATIONS

Model	Rated Capacity (Tons)	Pulling Capacity (Tons)	Rated Forward Travel (mm)	Efficient Length of forward handle (mm)	Rope Dia (mm)	Standard Length of Rope	Net Weight (Kg)	Rated forward Hand power (N)	Max overall size (mm)
LMRW-0.8	0.8	1.2	>=52	825	8.3	20	16	<=341	426x238x64
LMRW-1.6	1.6	2.4	>=55	1200	11	20	24	<=400	545x284x97
LMRW-3.2	3.2	4.8	>=28	1200	16	20	32	<=438	660x325x98
LMRW-5.4	5.4	8.1	>=25	1200	20	20	90	<=550	930x390x150

RATCHET LOAD BINDER

Model: LMLB(R)

Technical Features

- Safety, reliable design for easy operation
- Designed for heavy duty transport use
- High quality drop forged and heat treated for extra strength
- Each binder individually proof tested

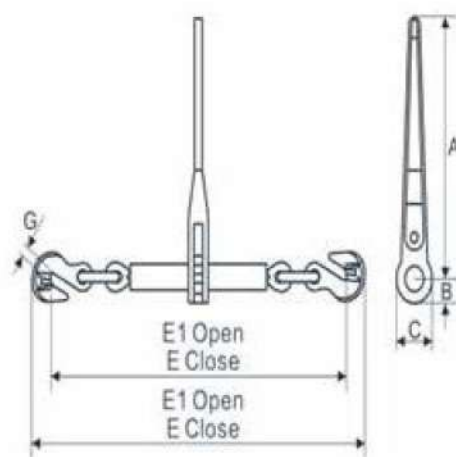

RATCHET TYPE LOADBINDER SPECIFICATION

Model	Chain size (in)	WLL (Tons)	Proof Load (Tons)	Min Ultimate Load (Tons)	Wt Kg	Handle Length (in)	Dimension(in)						
							A	B	C	E	E1	F	F1
LMLB(R-02)	1/4"-5/16"	1.3	2.6	3.9	1.6	7.16	7.16	0.89	1.77	16.2	21.2	17.7	22.8
LMLB(R-05)	5/16"-3/8"	2.7	5.4	9.5	4.75	13.42	13.9	1.3	2.6	22.6	30.6	25.2	33.2
LMLB(R-09)	3/8"-1/2"	4.6	9.2	16.5	5.85	13.92	13.9	1.3	2.6	24.1	32.1	27	35
LMLB(R-11)	1/2"-5/8"	5.5	11	23	6.52	13.92	13.9	1.3	2.6	26.4	34.4	30	38

PLAIN TROLLEY

Model: LMPT

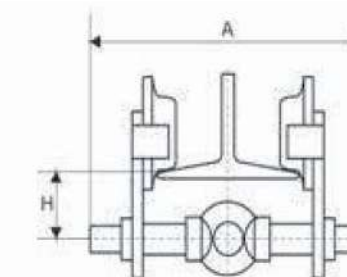
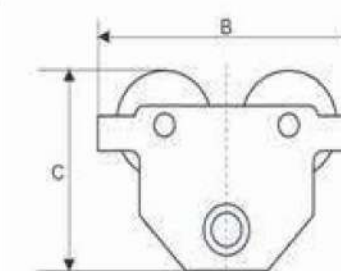

Model No	WLL (Tons)	I-Beam Width (mm)	Min turning Radius (m)	N.W/KGS	A (mm)	B (mm)	(mm)	H (mm)
LMPT-50	0.5	50-220	0.9	5.5	290	212	166	67
LMPT-01	1	58-220	1.0	8.7	300	238	189	74
LMPT-02	2	66-220	1.1	14.6	300	277	220	92
LMPT-03	3	74-220	1.3	24.5	321	330	283	119
LMPT-05	5	90-220	1.4	34.5	415	346	305	126

GEARED TROLLEY

Model: LMPT

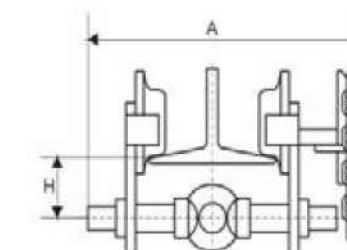
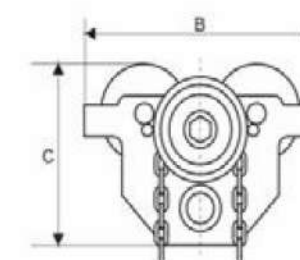

Model No	WLL (Tons)	I-Beam width (mm)	Min turning radius (m)	N.W/KGS	A (mm)	(mm)	C (mm)	H (mm)
LMGT-50	0.5	50-220	0.9	9	352.5	212	166	67
LMGT-01	1	58-220	1.0	12.6	353.5	238	189	74
LMGT-02	2	66-220	1.1	18.5	355	270	220	92
LMGT-03	3	74-220	1.3	30	400	330	283	119
LMGT-05	5	90-220	1.4	41	420	346	305	126

BEAM CLAMP

Model: LMBC

Technical Features

- Flexible application due to wide adjustment range
- Gives quick and versatile rigging for hoisting equipment, pulley blocks or loads
- The central threaded spindle allows easy attachment and a safe secure grip.
- Spindle can be secured against loosening.

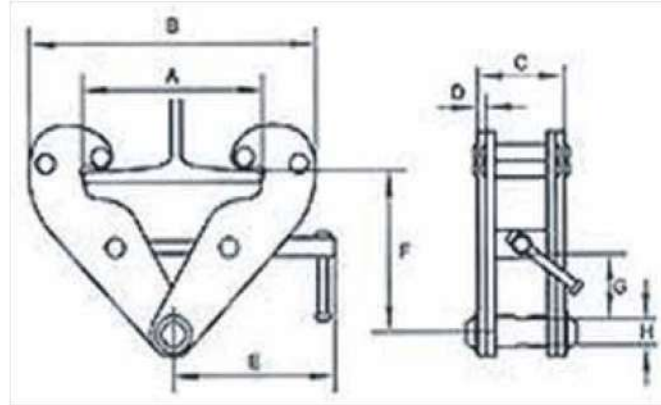

Beam Clamp Specifications

Model No	WLL (Tons)	Jaw Opening (mm)	A		B		C (mm)	D (mm)	E (mm)	F		G		H (mm)
			Min (mm)	Max (mm)	Min (mm)	Max (mm)				Min (mm)	Max (mm)	Min (mm)	Max (mm)	
LMBG01	01	75-220	70	300	165	385	67	4	230	70	160	16	70	22
LMBG02	02	75-220	70	300	165	385	75	6	230	70	160	16	70	22
LMBG03	03	80-320	70	388	230	508	100	8	265	130	230	32	110	25
LMBG05	05	80-320	70	388	230	508	108	10	265	130	230	32	110	25
LMBG10	10	90-320	82	440	270	590	117	12	325	170	275	60	135	35
LMBG20	20	90-320	105	485	385	710	135	16	365	220	330	70	170	54

PERMANENT TYPE MAGNETIC LIFTER

Model: LM-PML

Technical Features

This permanent magnets operate independently of a power supply. Due to the specific arrangement of a group of permanent magnets, the magnet field lines act on the magnet pole and the load, or are deflected in the magnet housing so that the poles are not magnetized. In position "ON", the magnetic field lines are guided via the poles through the load. The magnet is active. In position "OFF", the magnet pole surfaces are neutral and the magnet is therefore switched off. The load lifting magnet consists of individual standardized components. The inside of the magnet comprises the actual magnet system consisting of a reversing magnet system, the magnet assembly and the magnet poles.

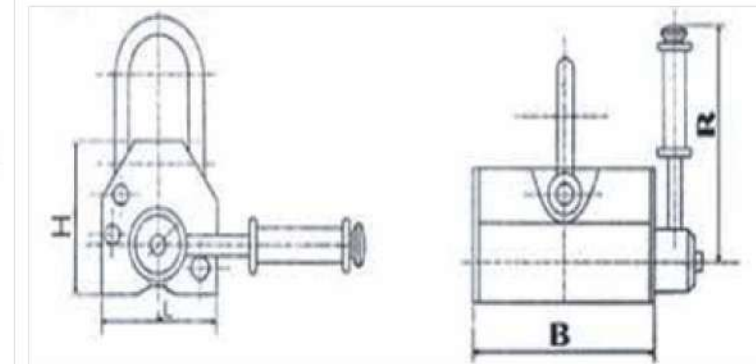

PERMANENT TYPE MAGNETIC LIFTER SPECIFICATIONS

Model No	WLL (Kg)	Cylindrical Lifting Capacity (Kg)	Max Pull-off Strength (Kg)	N.W/KGS	L (mm)	B (mm)	H (mm)	R (mm)
LM-PML(01)	100	30	350	3	62	92	70	145
LM-PML(03)	300	100	1050	10	92	162	96	180
LM-PML(05)	500	150	1750	20	120	216	118	220
LM-PML(06)	600	200	2100	24	122	232	120	220
LM-PML(10)	1000	300	3500	50	176	258	163	285
LM-PML(20)	2000	600	7000	125	234	378	212	465
LM PML(30)	3000	1000	10500	220	286	458	261	565

G-80 LIFTING CHAIN

Model: LMCH

Technical Features

- High quality alloy steel chain
- Surface finish: self-color, black finish
- Proof load: 200% WLL
- Factor of safety is 4:1
- Confirming to standard EN 818-2

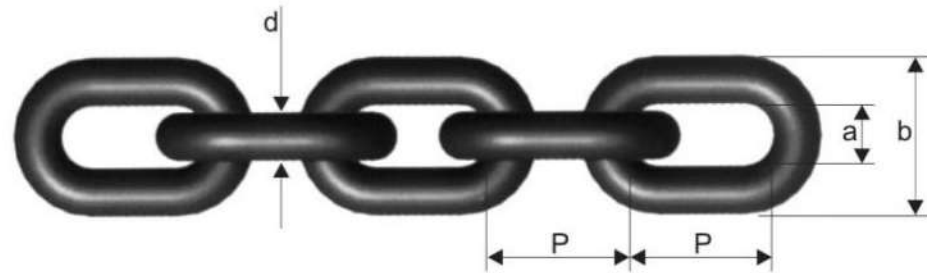

G-80 LIFTING CHAIN SPECIFICATION

Part No.	Size (mm)	Width(mm)		WLL (Tons)	Test Load KN	Min Breaking Load KN	Weight Kg/m
		Inside min(a)	Outside max(b)				
LMCH-06	6X18	7.5	21	1.1	27	45.2	0.79
LMCH-08	8X24	10	28	2	48	80.4	1.38
LMCH-10	10X30	12.5	35	3.2	76	125	2.2
LMCH-13	13X39	18	44	5.4	128	214	3.8
LMCH-16	16X48	20	56	8.2	192	320	5.63
LMCH-16	16X49	24.5	59.5	8.2	192	320	8.71
LMCH-16	16X64	23.9	58.9	8.2	246	320	5.11
LMCH-18	18X54	23	63	10	246	410	6.85
LMCH-18	18X64	21	60	10	246	410	6.6
LMCH-20	20X60	25	70	12.8	300	450	8.6
LMCH-22	22X65	28	74.2	15.4	366	610	10.7
LMCH-22	22X66	28	77	15.4	366	610	10.2
LMCH-22	22X86	26	74	15.4	366	610	9.5
LMCH-26	26X28	35	91	21.6	510	850	14.87
LMCH-26	26X92	30	86	21.6	510	850	13.7
LMCH-32	32X96	40	106	32.7	772	1286	22.29

CARGO LASHING BELT

Model: LM-CLB

Technical Features

- 100% High tenacity of polyester lashing strap
- Low elongation
- Width available : 1" - 4"
- Standard length : 10 mtrs and also can be customized on requirement
- Breaking strength scope : 1T - 10T
- Meets standard EN 12195-2
- End fitting-Double J Hook, Fasteners-Ratchet



CLEVIS SLING HOOK WITH LATCH SPECIFICATIONS

Model No.	Webbing width (inch)	M Breaking Load (Tons)	Lashing Capacity (Tons)
LM-CLB(01)	1"	1.0	0.5
LM-CLB(04)	2"	5.0	2.5
LM-CLB(08)	3"	8.0	4.0
LM-CLB(10)	4"	10.0	5.0

MASTER LINK

Model: LMML

Technical Features

- Forged or welded super alloy steel
- Suitable for use with Gr.80 chain
- Meets standard EN 1677
- Used for 1 or 2 legs wire rope/chain slings
- Individually proof tested at 2.5 times of the working load limit
- Factor of safety is 4:1

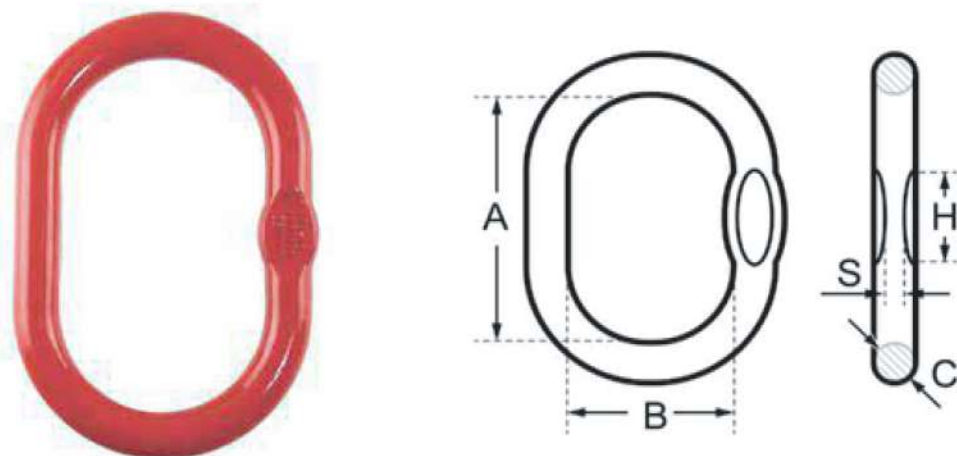

MASTER LINK SPECIFICATIONS

Model No	Weight (kg)	WLL(Ton)	A	B	C	S	H
LMML-13B5	0.3	2.6	95	51	13	7	50
LMML-13B6	0.35	2.4	115	60	13	7	50
LMML-16B6	0.6	3.8	120	70	16	9	70
LMML-16B7	0.86	2.8	190	100	16	9	70
LMML-20B6	1.1	6.4	150	80	20	11	50
LMML-20B7	1.25	5.8	170	90	20	11	70
LMML-22B6	1.53	7.6	170	90	22	12	70
LMML-22B7	1.83	6.4	210	110	22	12	70
LMML-25B6	2.21	10	190	100	25	13	80
LMML-28B6	3.06	12.7	210	110	28	15	80
LMML-28B7	3.81	10.5	270	140	28	15	70
LMML-32B6	5.05	15.2	270	140	32	17	70
LMML-38B6	7.3	25.1	270	140	38	20	55
LMML-38B7	10.78	17	420	220	38	20	55
LMML-45B6	12.2	34	320	170	45	24	60
LMML-45B7	17.06	24.5	470	250	45	24	60
LMML-50B6	17.65	40	380	200	50	-	-
LMML-60B6	28.85	58	430	220	60	-	-
LMML-70B6	45.48	84	500	250	70	-	-

MASTER LINK ASSEMBLY

Model: LMMA

Technical Features

- Forged or welded super alloy steel
- Suitable for use with Gr.80 chain
- Meets standard EN 1677
- Uses for 3 or 4 legs wire rope/chain slings
- Individually proof tested at 2.5 times working load limit
- Factor of safety is 4:1

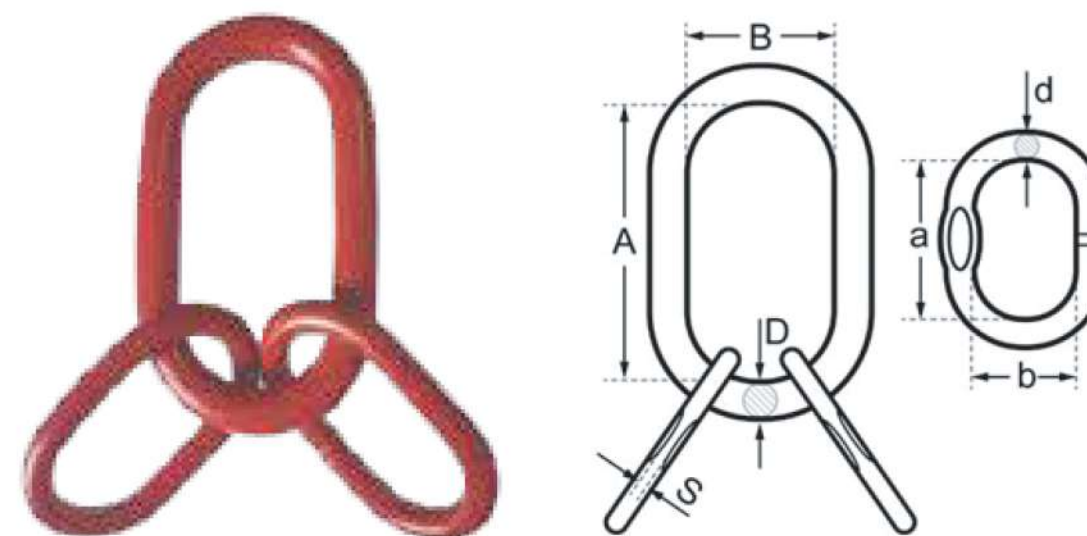

MASTER LINK SPECIFICATIONS

Model No	Weight (kg)	WLL(Ton)	A	B	D	a	b	d
LMMA-16	1.19	3.8	120	70	16	95	51	13
LMMA-20	2.41	5.8	170	90	20	120	70	16
LMMA-22	3.77	7.6	170	90	22	150	80	20
LMMA-25	4.45	10	190	100	25	150	80	20
LMMA-28	6.12	12.7	210	110	28	170	90	22
LMMA-32	9.47	15.2	270	140	32	190	100	25
LMMA-38	17.4	25	270	140	38	270	140	32
LMMA-45	26.76	34	320	170	45	270	140	38

CLEVIS SLING HOOK WITH LATCH

Model: LM-CSH

Technical Features

- Forged super alloy steel – Quenched & Tempered
- Fatigue tested at 1.5 times the WLL for 2000 cycles
- Designed to use for Gr.80 alloy steel chain
- Meets standard EN 818-2
- Individually proof tested at 2.5 times working load limit
- Factor of safety is 4:1
- 100% Magnaflux crack detection

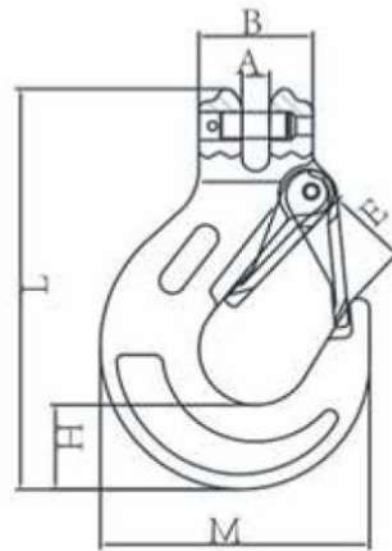

CLEVIS SLING HOOK WITH LATCH SPECIFICATIONS

Model No	WLL (Tons)	A (mm)	B (mm)	H (mm)	E (mm)	L (mm)	Net Wt (Kg)
LM-CSH(08)	2	9.5	37	32	29	118	0.52
LM-CSH(10)	3.15	13	50	35	39	139	1.05
LM-CSH(13)	5.3	16.5	56	43	47	170	2
LM-CSH(16)	8	21.5	70	54	55	204	3.7
LM-CSH(20)	12.5	24	75	58	61	238	6
LM-CSH(22)	15	27	91	62	72	275	10.4
LM-CSH(26)	21.2	30	118	74	85	325	14.5
LM-CSH(32)	31.5	55	149	86	106	405	27

CLEVIS SELF LOCKING HOOK

Model: LM-CSL

Technical Features

- Forged or welded super alloy steel
- Fatigue tested at 1.5 times the WLL for 2000 cycles
- Suitable for use with Gr.80 alloy steel chain
- Meets standard EN 1667
- All clevis self-locking hook are Individually proof tested at 2.5 times working load limit
- Factor of safety is 4:1
- 100% Magnaflux crack detection

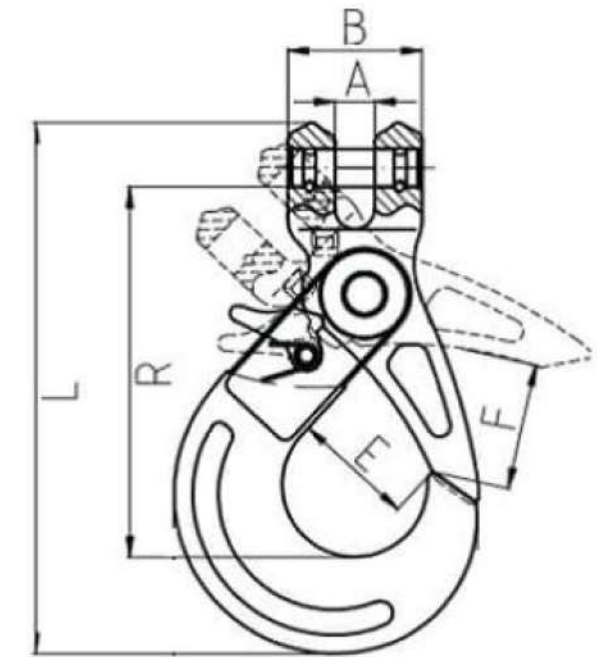

CLEVIS SELF LOCKING HOOK SPECIFICATIONS

Model No	WLL (Tons)	A (mm)	B (mm)	F (mm)	E (mm)	L (mm)	R (mm)	Net Wt (Kg)
LM-CSL(08)	2	9.5	38	40	35	160	120	0.8
LM-CSL(10)	3.15	12	46	52	46	195	140	1.5
LM-CSL(13)	5.3	15	59	62	52	250	180	2.8
LM-CSL(16)	8	18	77	66	64	310	225	5.6
LM-CSL(20)	12.5	24	77	81	85	335	240	7.5
LM-CSL(22)	15	24	97	84	74	390	277	11.5
LM-CSL(26)	21.2	31	113	105	95	450	312	18.5
LM-CSL(32)	31.5	35	150	140	134	590	415	45

CLEVIS GRAB HOOK

Model: LMCG8

Technical Features

- Forged or welded super alloy steel
- Fatigue tested at 1.5 times the WLL for 2000 cycles
- Suitable for use with Gr.80 alloy steel chain
- All load pins are 100 Individually inspected and tested
- Meets standard EN 1667
- All clevis self-locking hook are Individually proof tested at 2.5 times working
- Factor of safety is 4:1
- 100% Magnaflux crack detection

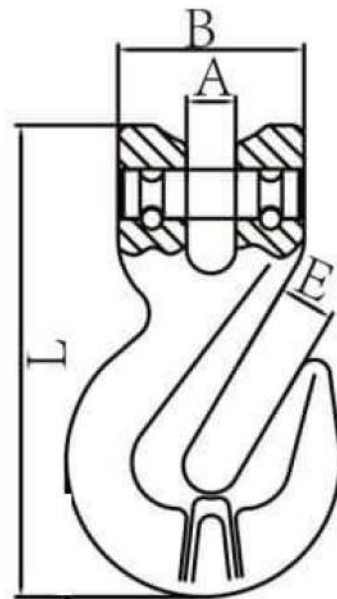

CLEVIS SELF LOCKING HOOK SPECIFICATIONS

Model No	WLL (Tons)	A (mm)	B (mm)	F (mm)	E (mm)	L (mm)	R (mm)	Net Wt (Kg)
LM-CSL(08)	2	9.5	38	40	35	160	120	0.8
LM-CSL(10)	3.15	12	46	52	46	195	140	1.5
LM-CSL(13)	5.3	15	59	62	52	250	180	2.8
LM-CSL(16)	8	18	77	66	64	310	225	5.6
LM-CSL(20)	12.5	24	77	81	85	335	240	7.5
LM-CSL(22)	15	24	97	84	74	390	277	11.5
LM-CSL(26)	21.2	31	113	105	95	450	312	18.5
LM-CSL(32)	31.5	35	150	140	134	590	415	45

EYE GRAB HOOK

Model: LMEG8

Technical Features

- Forged or welded super alloy steel
- Fatigue tested at 1.5 times the WLL for 2000 cycles
- Suitable for use with Gr.80 alloy steel chain
- Meets standard EN 1667
- All clevis self-locking hook are Individually proof tested at 2.5 times working load limit
- Factor of safety is 4:1
- 100% Magnaflux crack detection

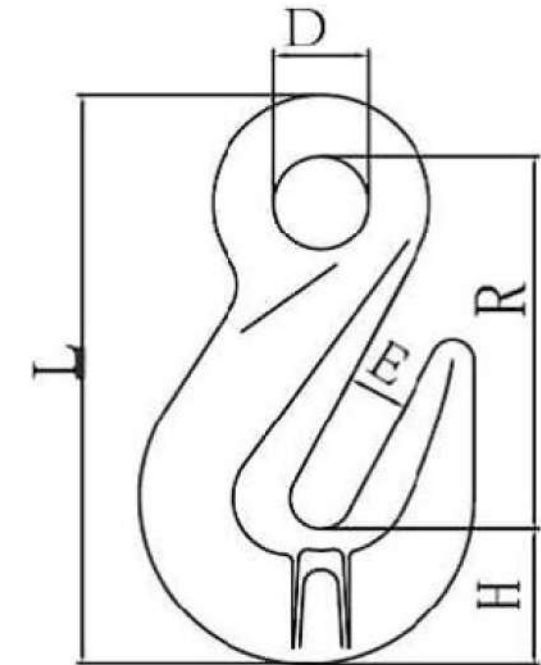

CLEVIS GRAB HOOK SPECIFICATIONS

Model No	WLL (Tons)	E (mm)	D (mm)	H (mm)	R (mm)	L (mm)	Net Wt
LMEG8-06	1.2	8	13	19	54	81	0.22
LMEG8-08	2	9.5	15	23	64	98	0.31
LMEG8-10	3.2	12.5	20	30	82	125	0.7
LMEG8-13	5.4	17	25	42	106	165	1.8
LMEG8-16	8.2	20	30	49	127	196	3.1
LMEG8-20	12.8	23	34.5	56	152	231	4.1
LMEG8-22	15.5	28	40.5	65	175	257	6.2

EYE SLING HOOK WITH LATCH

Model: LM-ESH

Technical Features

- Forged super alloy steel – Quenched & Tempered
- Fatigue tested at 1.5 times the WLL for 2000 cycles
- Designed to use for Gr.80 alloy steel chain
- Meets standard EN 818-2
- Individually proof tested at 2.5 times working load limit
- Factor of safety is 4:1
- 100% Magnaflux crack detection

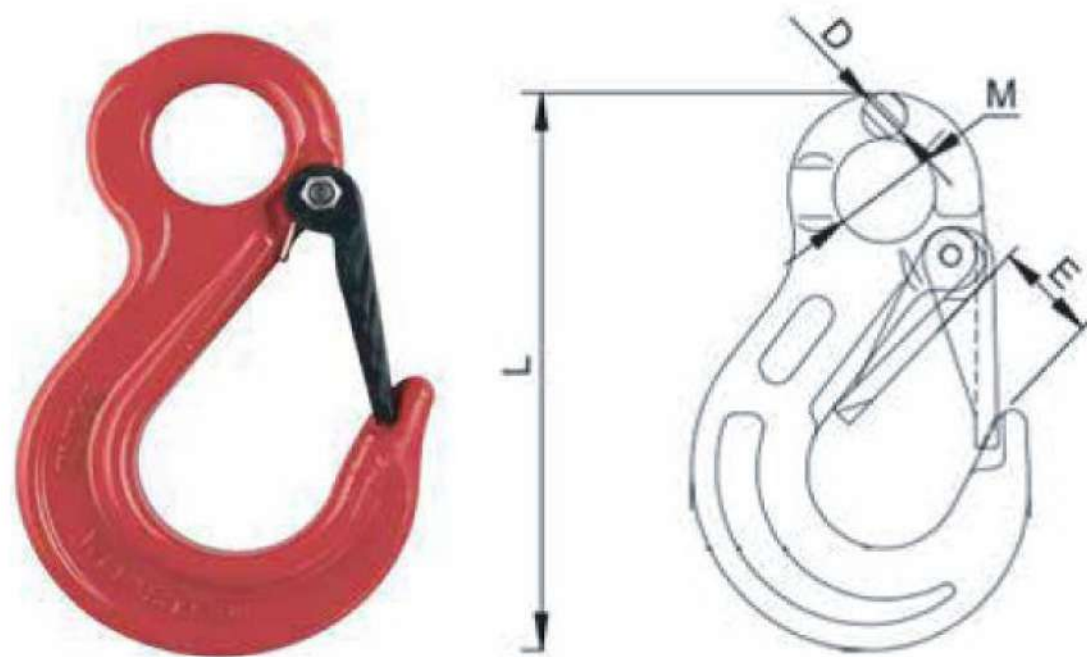

CLEVIS SLING HOOK WITH LATCH SPECIFICATIONS

Model No	WLL (Tons)	M (mm)	D (mm)	E (mm)	L (mm)	(Kg)
LM-ESH(08)	2	25	11	30	132	0.55
LM-ESH(10)	3.15	38	16	33	165	1.05
LM-ESH(13)	5.3	42	19	40	210	1.75
LM-ESH(16)	8	49	22	43	254	3.2
LM-ESH(20)	12.5	61	26	39	304	5.3
LM-ESH(22)	15	61	31	72	347	9.0
LM-ESH(26)	21.2	65	36	81	390	13
LM-ESH(32)	31.5	88	38	102	480	17

CLEVIS SHORTENING CLUTCH

Model: LMSC

Technical Features

- Forged super alloy steel – Quenched & Tempered
- Suitable for use with Gr.80 chain
- Meets standard EN 818-2
- Individually proof tested at 2.5 times working load limit
- Factor of safety is 4:1
- 100% Magnaflux crack detection

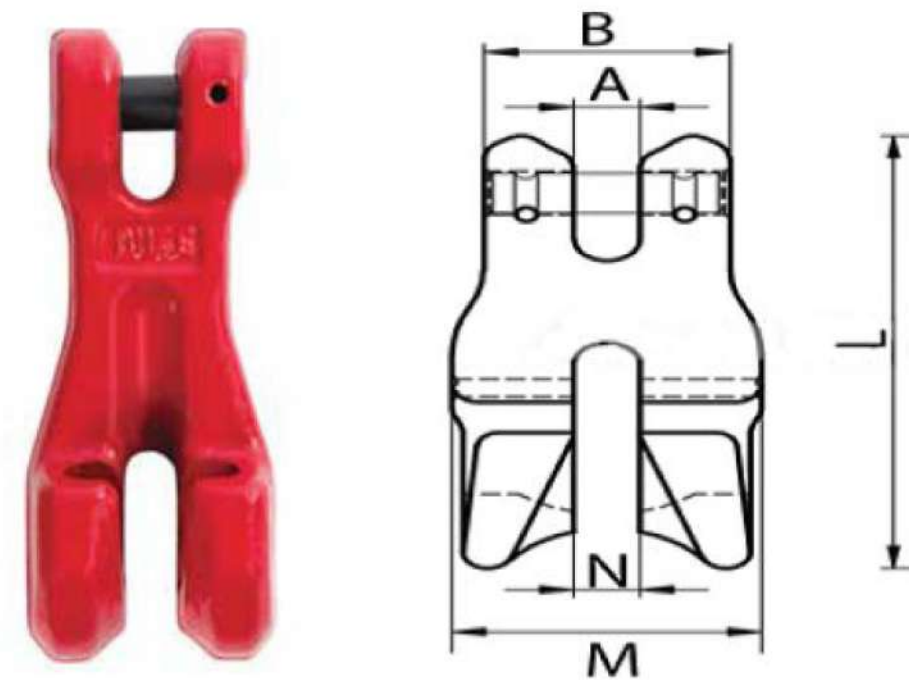

CLEVIS SHORTENING CLUTCH SPECIFICATION

Model No	WLL (Tons)	N (mm)	A (mm)	M (mm)	B (mm)	L (mm)	Net Wt (Kg)
LMSC-08	2	9.5	9.5	45	36	101	0.37
LMSC-10	3.15	13	13	55	48	138	0.97
LMSC-13	5.3	16	16	75	59	177	2.01
LMSC-16	8	21	21	93	73	220	3.32
LMSC-20	12.5	22	22	99	78	238	6.2
LMSC-22	15	25.5	25.5	118	98	295	8.5

BOLT TYPE ANCHOR SHACKLE

Anchor Shackles Bolt Type, Forged Alloy Steel, High Tensile Strength.

- Finished** : Anchor Shackles are supplied in hot dip gray galvanized.
- Working Load Limit** : Permanently shown on every Shackle.
- Shackle Material** : High Tensile Steel Forged – Quenched and Tempered, Grade 6.
- Shackle Size** : Capacities 1/3 thru 150 metric tons.

Meets the performance requirements of Federal Specification RR-C-271D Type IVA, Grade A, Class 2 and EN13889 except for those provisions required of the contractor.

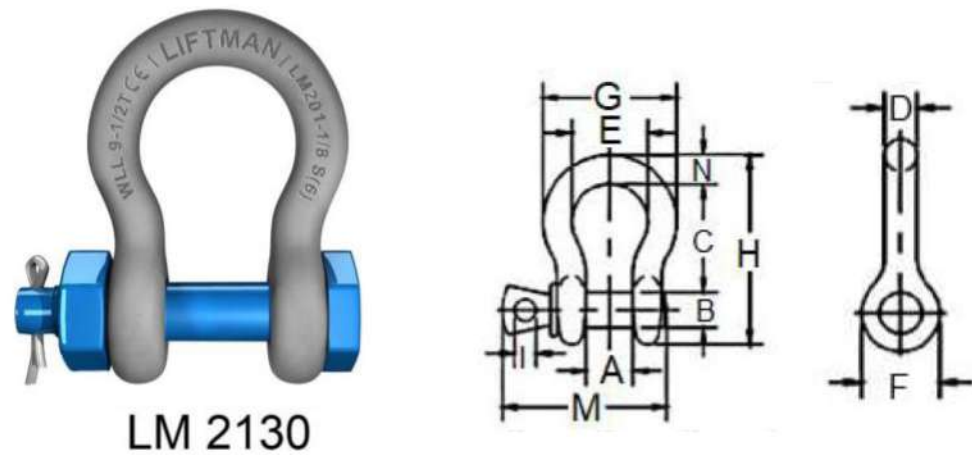

Nominal Size	Working Load Limit	Dimensions (mm)								Weight each
		A	B	C	D	E	F	G	H	
3/16	1/3	9.65	6.35	22.4	4.85	15.2	14.2	37.2	24.9	0.03
1/4	1/2	11.9	7.85	28.7	6.35	19.8	15.5	46.7	32.5	0.05
5/16	3/4	13.5	9.65	31.0	7.85	21.3	19.1	53.0	37.3	0.10
3/8	1	16.8	11.2	36.6	9.65	26.2	23.1	63.0	45.2	0.15
7/16	1-1/2	19.1	12.7	42.9	11.2	29.5	26.9	74.0	51.5	0.22
1/2	2	20.6	16.0	47.8	12.7	33.3	30.2	83.5	58.5	0.36
5/8	3-1/4	26.9	19.1	60.5	16.0	42.9	38.1	106	74.5	0.76
3/4	4-3/4	31.8	22.4	71.5	19.1	51.0	46.0	126	89.0	1.23
7/8	6-1/2	36.6	25.4	84.0	22.4	58.0	53.0	148	102	1.79
1	8-1/2	42.9	28.7	95.5	25.4	68.5	60.5	167	119	2.57
1-1/8	9-1/2	46.0	31.8	108	28.7	74.0	68.5	190	131	3.75
1-1/4	12	51.5	35.1	119	31.8	82.5	76.0	210	146	5.31
1-3/8	13-1/2	57.0	38.1	133	35.1	92.0	84.0	233	162	7.18
1-1/2	17	60.5	41.4	146	38.1	98.5	92.0	254	175	9.43
1-3/4	25	73.0	51.0	178	44.5	127	106	313	225	15.4
2	35	82.5	57.0	197	51.0	146	122	348	253	23.7
2-1/2	55	105	70.0	267	66.5	184	145	453	327	44.6
3	85	127	82.5	330	76.0	200	165	546	365	70
3-1/2	120	133	95.5	372	92.0	229	203	626	419	120
4	150	140	108	368	104	254	229	653	468	153



- *Maximum Proof Load is 2 times the Working Load Limit.
- *Minimum Ultimate Strength is 6 times the Working Load Limit.

BOLT TYPE CHAIN SHACKLE

Chain Shackle Bolt Type, Forged Alloy Steel, High Tensile Strength.

- Finished** : Anchor Shackles are supplied in hot dip gray galvanized.
- Working Load Limit** : Permanently shown on every Shackle.
- Shackle Material** : High Tensile Steel Forged – Quenched and Tempered, Grade 6.
- Shackle Size** : Capacities 1/3 thru 85 metric tons.

Meets the performance requirements of Federal Specification RR-C-271D Type IVA, Grade A, Class 2 and EN13889 except for those provisions required of the contractor.

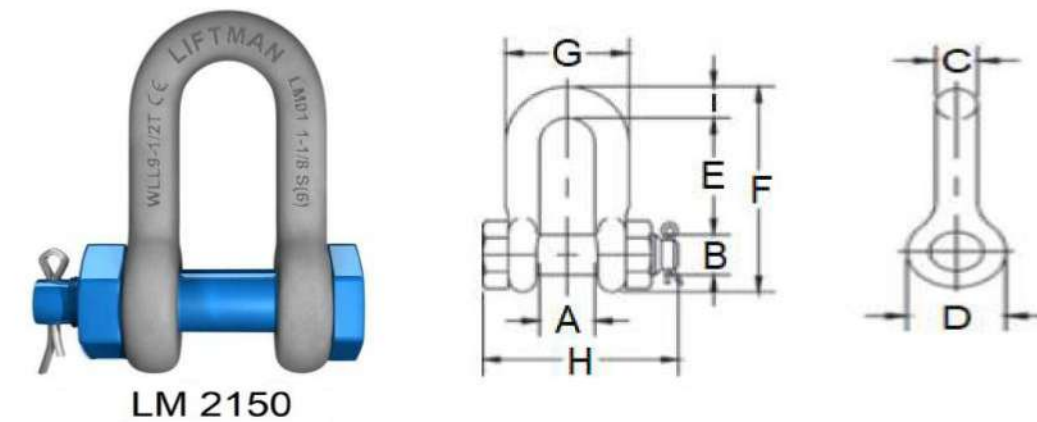

Nominal Size	Working Load Limit	Dimensions (mm)								Weight each	
		A	B	C	D	E	F	G	H		I
1/4"	1/2	11.9	7.85	6.35	15.5	19.1	40.4	24.6	39.6	6.35	0.06
5/16	3/4	13.5	9.65	7.85	19.1	25.4	48.5	29.5	46.2	7.85	0.10
3/8	1	16.8	11.2	9.65	23.1	31.0	58.5	35.8	55.0	9.65	0.15
7/16	1-1/2	19.1	12.7	11.2	26.9	36.1	67.5	41.1	63.5	11.2	0.22
1/2	2	20.6	16.0	12.7	30.2	41.4	77.0	46.0	71.0	12.7	0.34
5/8	3-1/4	26.9	19.1	16.0	38.1	51.0	95.5	58.5	89.5	16	0.67
3/4	4-3/4	31.8	22.4	19.1	46.0	60.5	115	70.0	103	20.6	1.14
7/8	6-1/2	36.6	25.4	22.4	53.0	71.5	135	81.0	120	24.6	1.74
1	8-1/2	42.9	28.7	25.4	60.5	81.0	151	93.5	135	25.4	2.52
1-1/8	9-1/2	46.0	31.8	28.7	68.5	91.0	172	103	150	31.8	3.45
1-1/4	12	51.5	35.1	31.8	76.0	100	191	115	165	35.1	4.90
1-3/8	13-1/2	57.0	38.1	35.1	84.0	111	210	127	183	38.1	6.24
1-1/2	17	60.5	41.4	38.1	92.0	122	230	137	196	41.1	8.39
1-3/4	25	73.0	51.0	44.5	106	146	279	162	230	54.0	14.2
2	35	82.5	57.0	51.0	122	172	312	184	264	51.0	21.2
2-1/2	55	105	70.0	66.5	145	203	377	238	344	66.5	38.6
3	85	127	82.5	76.0	165	216	429	279	419	89.0	56



- *Maximum Proof Load is 2 times the Working Load Limit.
- *Minimum Ultimate Strength is 6 times the Working Load Limit.

SCREW PIN ANCHOR SHACKLE

Anchor Shackles with Screw Collar Pin, Forged Alloy Steel, High Tensile Strength.

- Finished** : Anchor Shackles are supplied in hot dip gray galvanized.
- Working Load Limit** : Permanently shown on every Shackle.
- Shackle Material** : High Tensile Steel Forged – Quenched and Tempered, Grade 6.
- Shackle Size** : Capacities 1/3 thru 55 metric tons.

Meets the performance requirements of Federal Specification RR-C-271D Type IVA, Grade A, Class 2 and EN13889 except for those provisions required of the contractor.

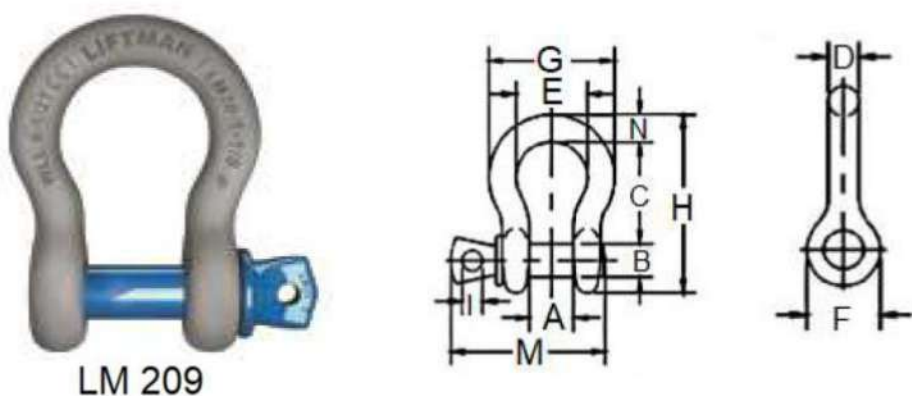

Nominal Size	Working Load Limit	Dimensions (mm)											Weight each
INCH	TONS	A	B	C	D	E	F	G	H	I	M	N	KG
3/16	1/3	9.65	6.35	22.4	4.85	15.2	14.2	24.9	37.3	4.06	28.4	4.85	0.03
1/4	1/2	11.9	7.85	27.8	6.35	19.8	15.5	32.5	46.7	4.85	35.1	6.35	0.05
5/16	3/4	13.5	9.65	31.0	7.85	21.3	19.1	37.5	53.0	5.60	42.2	7.85	0.09
3/8	1	16.8	11.2	36.6	9.65	26.2	23.1	45.2	63.0	6.35	51.5	9.65	0.14
7/16	1-1/2	19.1	12.7	42.9	11.2	29.5	26.9	51.5	74.0	7.85	60.5	11.2	0.17
1/2	2	20.6	16.0	47.8	12.7	33.3	30.2	58.5	83.5	9.65	68.5	12.7	0.33
5/8	3-1/4	26.9	19.1	60.5	16.0	42.9	38.1	74.5	106	11.2	85.0	17.5	0.62
3/4	4-3/4	31.8	22.4	71.5	19.1	51.0	46.0	89.0	126	12.7	101	20.6	1.07
7/8	6-1/2	36.6	25.4	84.0	22.4	58.0	53.0	102	148	12.7	114	24.6	1.64
1	8-1/2	42.9	28.7	95.5	25.4	68.5	60.5	119	167	14.2	129	26.9	2.28
1-1/8	9-1/2	46.0	31.8	108	29.5	74.0	68.5	131	190	16.0	142	31.8	3.36
1-1/4	12	51.5	35.1	119	32.8	92.5	76.0	146	210	17.5	156	35.1	4.31
1-3/8	13-1/2	57.0	38.1	133	36.1	92.0	84.0	162	233	19.1	174	38.1	6.14
1-1/2	17	60.5	41.4	146	39.1	98.5	92.0	175	254	20.6	187	41.1	7.80
1-3/4	25	73.0	51.0	178	46.7	127	106	225	313	25.4	231	57.0	12.6
2	35	82.5	57.0	197	53.0	146	122	253	348	31.0	263	61.0	20.4
2-1/2	55	105	70.0	267	69.0	184	145	327	453	35.1	330	79.5	38.9



*Maximum Proof Load is 2 times the Working Load Limit.
*Minimum Ultimate Strength is 6 times the Working Load Limit.

SCREW PIN CHAIN SHACKLE

Chain Shackles with Screw Collar Pin, Forged Alloy Steel, High Tensile Strength.

- Finished** : Chain Shackles are supplied in hot dip gray galvanized.
- Working Load Limit** : Permanently shown on every Shackle.
- Shackle Material** : High Tensile Steel Forged – Quenched and Tempered, Grade 6.
- Shackle Size** : Capacities 1/4 thru 55 metric tons.

Meets the performance requirements of Federal Specification RR-C-271D Type IVA, Grade A, Class 2 and EN13889 except for those provisions required of the contractor.

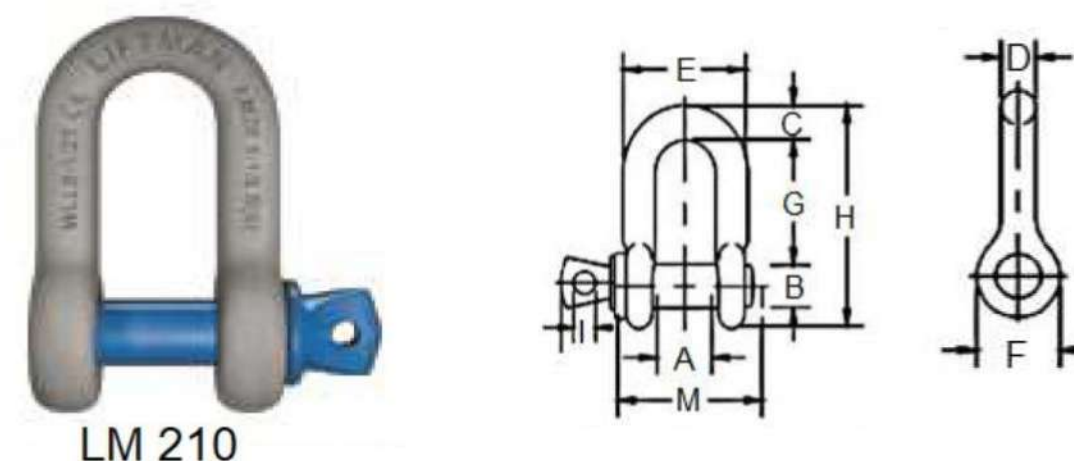

Nominal Size	Working Load Limit	Dimensions (mm)										Weight each
INCH	TONS	A	B	C	D	E	F	G	H	I	M	KG
1/4	1/2	11.9	7.85	6.35	6.35	24.6	15.5	22.4	40.4	4.85	35.1	0.05
5/16	3/4	13.5	9.65	7.85	7.85	29.5	19.1	26.2	48.5	5.60	42.2	0.08
3/8	1	16.8	11.2	9.65	9.65	35.8	23.1	31.8	58.5	6.35	51.5	0.13
7/16	1-1/2	19.1	12.7	11.2	11.2	41.4	26.9	36.6	67.5	7.85	60.5	0.20
1/2	2	20.6	16.0	12.7	12.7	46.0	30.2	41.4	77.0	9.65	68.5	0.27
5/8	3-1/4	26.9	19.1	15.7	16.0	58.5	38.1	51.0	95.5	11.2	85.0	0.57
3/4	4-3/4	31.8	22.4	20.6	19.1	70.0	46.0	60.5	115	12.7	101	1.20
7/8	6-1/2	36.6	25.4	24.6	22.4	81.0	53.0	71.5	135	12.7	114	1.43
1	8-1/2	42.9	28.7	25.4	25.4	93.5	60.5	81.0	151	14.2	129	2.15
1-1/8	9-1/2	46.0	31.8	31.8	28.7	103	68.5	91.0	172	16.0	142	3.06
1-1/4	12	51.5	35.1	35.1	31.8	115	76.0	100	191	17.5	156	4.11
1-3/8	13-1/2	57.0	38.1	38.1	35.1	127	84.0	111	200	19.1	174	5.28
1-1/2	17	60.5	41.4	41.1	38.1	137	92.0	122	230	20.6	187	7.23
1-3/4	25	73.0	51.0	54.0	44.5	162	106	146	279	25.4	231	12.1
2	35	82.5	57.0	51.0	51.0	184	122	172	312	31.0	263	19.2
2-1/2	55	105	70.0	66.5	66.5	238	145	203	377	35.1	330	32.5



*Maximum Proof Load is 2 times the Working Load Limit.
*Minimum Ultimate Strength is 6 times the Working Load Limit.

TURNBUCKLE WITH JAW-JAW END FITTING

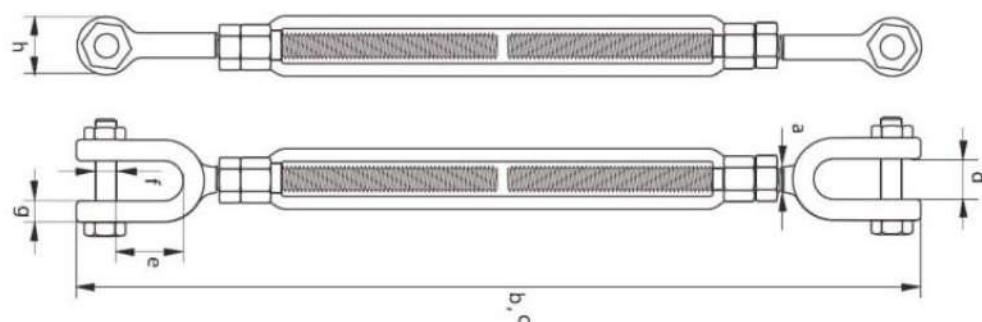

- Material** : Drop forged high tensile steel
Finish : Hot dip galvanized
WILL : Genrally to ASTM F1145-92
Packing : MBL=2xWLL | Proff load=2,5xWLL

Size	WLL t	Weight kg	Dimensions (mm)				
			a	b	c	d	e
1/4 x 4"	0.23	0.16	6.35	302.26	200.66	11.43	15.75
5/16 x 11/2"	0.36	0.24	7.874	353.06	238.76	12.7	22.1
3/8 x 6"	0.54	0.37	9.652	441.45	289.05	13.72	22.1
1/2 x 6"	1	0.71	12.7	508	330.2	13.97	26.92
1/2 x 9"	1	0.79	12.7	660.4	406.4	13.97	26.92
1/2 x 12"	1	1.09	12.7	812.8	482.6	13.97	26.92
5/8 x 6"	1.59	1.23	16.002	562.1	377.95	20.83	33.27
5/8 x 9"	1.59	1.56	16.002	714.5	454.15	20.83	33.27
5/8 x 12"	1.59	1.77	15.002	866.9	539.35	20.83	33.27
3/4 x 6"	2.36	1.86	19.05	612.14	421.64	26.16	38.1
3/4 x 9"	2.36	2.48	19.05	764.54	497.84	26.16	38.1
3/4 x 12"	2.36	2.92	19.05	916.94	574.04	26.16	38.1
3/4 x 18"	2.36	3.66	19.05	1,221.74	726.44	26.16	38.1
7/8 x 12"	3.27	3.71	22.352	966.98	617.73	31.24	44.45
7/8 x 18"	3.27	4.89	22.352	1,271.78	770.13	31.24	44.45
1x 6"	4.54	4.62	25.4	712.72	509.52	33.27	52.32
1x 12"	4.54	5.68	25.4	1,017.52	661.92	33.27	52.32
1x18"	4.54	6.87	25.4	1,322.32	814.32	33.27	52.32
1X 24"	4.54	8.2	25.4	1,627.12	966.72	33.27	52.32
11/4 x 12"	6.89	9.34	31.75	1,118.62	750.32	47.24	71.37
11/4 x 18"	6.89	11.19	31.75	1,423.42	902.72	47.24	71.37
11/4 x 24"	6.89	12.79	31.75	1,728.22	1,055.12	47.24	71.37
11/2 x 12"	9.71	13.92	38.1	1,118.11	800.1	57.15	71.37
1/2 x 18"	9.71	16.67	38.1	1,485.9	952.5	57.15	71.37
11/2 x 24"	9.71	18.45	38.1	1,790.7	1,104.9	57.15	71.37
13/4 x 18"	12.7	24.49	44.45	1,503.17	1,045.97	66.04	85.85
13/4 x 24"	12.7	28.74	44.45	1,807.97	1,198.37	66.04	85.85
2 x 24"	16.78	42.75	50.8	1,948.69	1,339.09	66.55	93.73
2 1/2 x 24"	27.22	74.84	63.5	2,087.37	1,471.77	77.72	112.78
2 3/4 x 24"	34.02	89.81	69.85	2,171.7	1,562.1	93.47	106.43

TURNBUCKLE WITH EYE-EYE END FITTING

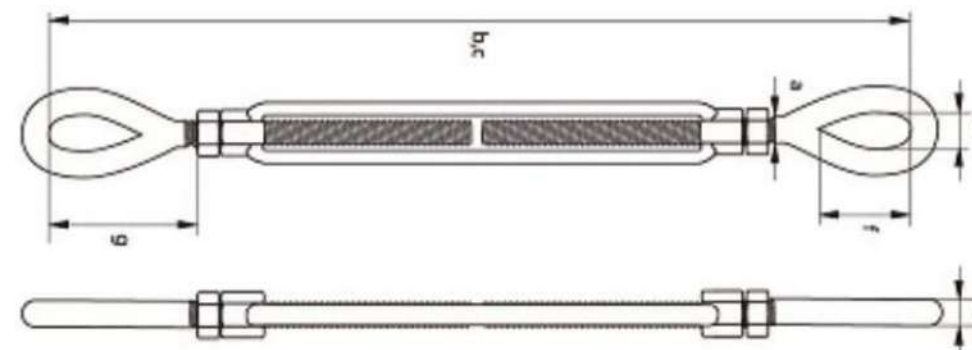

- Material** : Drop forged high tensile steel
Finish : Hot dip galvanized
WILL : Genrally to ASTM F1145-92
Packing : MBL=2xWLL | Proff load=2,5xWLL

Size	WLL t	Weight kg	Dimensions (mm)						
			a	b	c	d	e	f	g
1/4 x 4"	0.22	0.12	6.35	299.7	198.1	5.7	8.63	19.8	38.7
5/16 x 11/2"	0.36	0.2	7.87	344.4	230.1	7.1	11.17	23.8	45.9
3/8 x 6"	0.54	0.34	9.6	443.7	291.3	8.76	13.46	28.4	55.2
1/2 x 6"	0.99	0.69	12.7	510	332.2	11.17	18.28	36.06	70.8
1/2 x 9"	0.99	0.76	12.7	662	408.4	11.17	18.28	36.06	70.8
1/2 x 12"	0.99	0.97	12.7	814.8	484.6	11.17	18.28	36.06	70.8
5/8 x 6"	1.58	1.09	16	557	372.8	12.1	22.35	45.7	86.36
5/8 x 9"	1.58	1.28	16	709.4	449	12.7	22.35	45.7	86.36
5/8 x 12"	1.58	1.55	16	861.8	525.2	12.1	22.35	45.7	86.36
3/4 x 6"	2.35	1.12	19	606.5	416	15.7	25.4	53.08	103.4
3/4 x 9"	2.35	2.09	19	758.9	492.2	15.7	25.4	53.08	103.4
3/4 x 12"	2.35	2.48	19	911.3	568.4	15.7	25.4	53.08	103.4
3/4 x 18"	2.35	3.26	19	1,216	720.8	15.7	25.4	53.08	103.4
7/8 x 12"	3.26	3.27	22.35	941.5	592.3	19.05	31.75	60.4	110.49
7/8x18"	3.26	4.51	22.35	1,246.3	744.7	19.05	31.75	60.4	110.49
1X 6"	4.5	4.1	25.4	710.4	507.2	22.2	36.5	76.2	139.3
1X 12"	4.5	5.2	25.4	1,015	659.6	22.2	36.5	76.2	139.3
1x18"	4.5	6.3	25.4	1,320	812	22.2	36.5	76.2	139.3
1X 24"	4.5	7.8	25.4	1,624.8	964.4	22.2	36.5	76.2	139.9
11/4 x 12"	6.89	8.6	31.7	1,087.3	718.8	28.5	45.9	90.4	167.5
11/4 x 18"	6.89	10.4	31.7	1,392	871.4	28.5	45.9	90.4	167.5
11/4 x 24"	6.89	12.2	31.7	1,696.9	1,023.8	28.5	45.9	90.4	167.5
11/2 x 12"	9.7	12.4	38.1	1,155.7	774.7	31.7	53.8	103.1	187.2
11/2 x 18"	9.7	14	38.1	1,460.5	927	31.7	53.8	103.1	187.2
11/2 x 24"	9.7	17	38.2	1,765.3	1,079.5	31.7	53.8	103.1	187.2
13/4 x 18"	12.7	23.8	44.4	1,457.4	1,000.2	38.1	60.4	117.3	215.9
13/4 x 24"	12.7	26.3	44.4	1,762	1,152.6	38.1	60.4	117.3	215.9
2 X 24"	16.7	38.6	50.8	1,922.5	1,312.9	44.45	68.3	146	288
2 1/2 x 24"	27.02	65.4	64	1,996.9	1,387.3	50.8	79.2	165.1	299.2
23/4 x 24"	34	87.9	69.8	2,057.4	1,447.8	57.1	82.5	177.8	329.4

TURNBUCKLE WITH HOOK-HOOK END FITTING

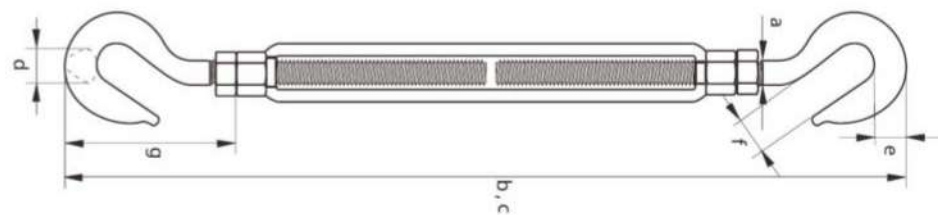

- Material** : Drop forged high tensile steel
- Finish** : Hot dip galvanized
- WILL** : Genrally to ASTM F1145-92
- Packing** : MBL=2xWLL | Proff load=2,5xWLL

Size	WLL t	Weig ht kg	Dimensions (mm)					
			a	b	c	e	f	g
1/4 x 4"	0.18	0.14	6.35	303.28	201.68	10.41	11.43	40.39
5/16 x 11/2"	0.32	0.21	7.87	350.77	236.47	12.7	12.7	49.28
3/8 x 6"	0.45	0.35	9.65	450.09	297.69	15.49	14.22	58.42
1/2 x 6"	0.68	0.73	12.7	517.65	339.85	19.81	16.76	74.68
1/2 x 9"	0.68	0.83	12.7	670.05	416.05	19.81	16.76	74.68
1/2 x 12"	0.68	1.03	12.7	822.45	492.25	19.81	16.76	74.68
5/8 x 6"	1.02	1.25	16	571.5	387.35	25.4	22.86	93.73
5/8 x 9"	1.02	1.53	16	723.9	463.55	25.4	22.86	93.73
5/8 x 12"	1.02	1.59	16	876.3	539.75	25.4	22.86	93.73
3/4 x 6"	1.36	1.76	19.05	629.41	438.91	30.48	24.89	114.81
3/4 x 9"	1.36	2.4	19.05	781.81	515.11	30.48	24.89	114.81
3/4 x 12"	1.36	2.46	19.05	934.21	591.31	30.48	24.89	114.81
3/4 x 18"	1.36	3.68	19.05	1,239.01	734.71	30.48	24.89	114.81
7/8 x 12"	1.81	3.67	22.35	984.25	635	34.93	28.7	131.83
7/8 x 18"	1.81	4.51	22.35	1,289.05	787.4	34.93	28.7	131.83
1x 6"	2.27	4.23	25.4	728.73	525.53	38.86	31.75	148.34
1X 12"	2.27	5.41	25.4	1,033.53	677.93	38.86	31.75	148.34
1X 18"	2.27	6.35	25.4	1,388.33	830.33	38.86	31.75	148.34
1X 24"	2.27	7.82	25.4	1,643.13	982.73	38.86	31.75	148.34
11/4 x 12"	2.95	9.34	31.75	1,119.12	750.82	45.97	38.1	183.39
11/4 x 18"	2.95	10.43	31.75	1,423.92	903.22	45.97	38.1	183.39
11/4 x 24"	2.95	12.25	31.75	1,728.72	1,055.62	45.97	38.1	183.39
11/2 x 12"	3.4	12.47	38.1	1,204.98	823.98	44.45	47.75	211.84
11/2 x 18"	3.4	14.06	38.1	1,509.78	976.38	44.2	47.75	211.84
11/2 x 24"	3.4	17.01	38.1	1,814.58	1,128.78	44.45	47.75	211.84

TURNBUCKLE WITH JAW-EYE END FITTING

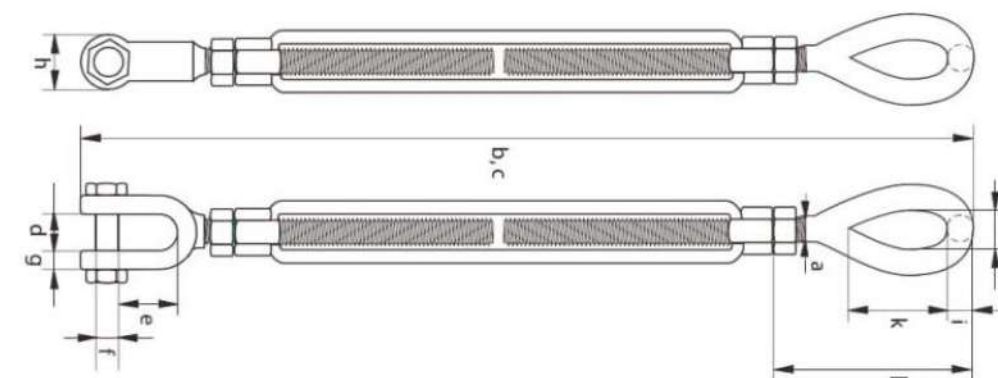

- Material** : Drop forged high tensile steel
- Finish** : Hot dip galvanized
- WILL** : Genrally to ASTM F1145-92
- Packing** : MBL=2xWLL | Proff load=2,5xWLL

Size	WLL t	Weight kg	Dimensions (mm)							
			a	b	c	d	e	j	k	l
1/4 x 4"	0.23	0.14	6.35	288.29	186.69	11.43	15.75	8.64	19.81	44.45
5/16 x 11/2"	0.36	0.23	7.87	348.23	221.23	12.7	22.1	11.18	23.88	53.09
3/8 x 6"	0.54	0.36	9.65	426.97	274.57	13.72	22.1	13.46	28.45	64.01
1/2 x 6"	1	0.68	12.7	489.97	312.17	13.97	26.92	18.29	36.07	82.04
1/2 x 9"	1	0.78	12.7	642.37	388.37	13.97	26.92	18.29	36.07	82.04
1/2 x 12"	1	0.94	12.7	794.77	464.57	13.97	26.92	18.29	36.07	82.04
5/8 x 6"	1.59	1.07	16	533.15	349	20.83	33.27	22.35	45.72	99.06
5/8 x 9"	1.59	1.44	16	685.55	425.2	20.83	33.27	22.35	45.72	99.06
5/8 x 12"	1.59	1.64	16	837.95	501.4	20.83	33.27	22.35	45.75	99.06
3/4 x 6"	2.36	1.81	19.05	576.33	385.83	26.16	38.1	25.40	53.09	119.13
3/4 x 9"	2.36	2.15	19.05	728.73	462.03	26.16	38.1	25.40	53.09	119.13
3/4 x 12"	2.36	2.69	19.05	881.13	538.23	26.16	38.1	25.40	53.09	119.13
3/4 x 18"	2.36	3.18	19.05	1,185.93	690.63	26.16	38.1	25.40	53.09	119.13
7/8 x 12"	3.27	3.79	22.35	916.69	567.44	31.24	44.45	31.75	60.45	129.54
7/8 x 18"	3.27	4.42	22.35	1,221.49	719.84	31.24	44.45	31.75	60.45	129.54
1x 6"	4.54	4.05	25.4	669.04	465.84	33.27	52.32	36.58	76.2	161.54
1X 12"	4.54	5.08	25.4	973.84	618.24	33.27	52.32	36.58	76.2	161.54
1x 18"	4.54	6.03	25.4	1,278.64	770.64	33.27	52.32	36.58	76.2	161.54
1X 24"	4.54	7.71	25.4	1,583.44	923.04	33.27	52.32	36.58	76.2	161.54
11/4 x 12"	6.89	8.81	31.75	1,049.53	681.23	47.24	71.37	45.97	90.42	196.09
11/4 x 18"	6.89	10.97	31.75	1,354.33	833.63	47.24	71.37	45.97	90.42	196.09
11/4 x 24"	6.89	12.93	31.75	1,659.13	986.03	47.24	71.37	45.97	90.42	196.09
11/2 x 12"	9.71	13.15	38.1	1,104.9	647.7	57.15	71.37	53.85	103.12	218.95
11/2 x 18"	9.71	15.88	38.1	1,409.7	876.3	57.15	71.37	53.85	103.12	218.95
11/2 x 24"	9.71	17.77	38.2	1,714.5	1,028.7	57.15	71.37	53.85	103.12	218.95
13/4 x 18"	12.7	24.38	44.45	1,406.65	949.45	66.04	85.85	60.45	117.35	254
13/4 x 24"	12.7	27.52	44.45	1,711.45	1,101.85	66.04	85.85	60.45	117.35	254
2 X 24"	16.78	40.37	50.8	1,844.55	1,234.95	66.55	93.73	68.33	146.05	332.49
2 1/2 x 24"	27.22	68.04	63.5	1,925.32	1,315.72	77.72	112.78	79.25	165.1	350.01
2 3/4 x 24"	34.02	83.01	69.85	1,978.15	1,368.55	93.47	106.43	82.55	177.8	386.59

WIRE ROPE CLIP LM 450

- Material** : Drop forged high tensile steel
Finish : Bridge - Hot dip galvanized, U-bolt – Electro plated
Standard : EN 13411-5 Type B
 Formerly U.S. Federal Specification FF-C-450D
Certificate : Manufacturer test certificate

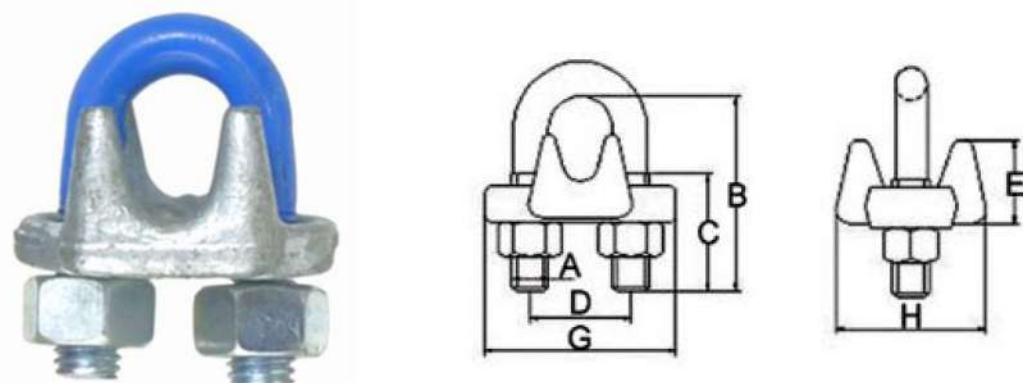

ITEM NO.	SIZE	A	B	C	D	E	F	G
LM-WRC0216	1/8	0.22	0.72	0.44	0.47	0.41	0.81	0.94
LM-WRC0316	3/16	0.25	0.97	0.56	0.59	0.5	0.94	1.16
LM-WRC0416	1/4	0.31	1.03	0.63	0.75	0.66	1.19	1.44
LM-WRC0516	5/16	0.38	1.23	0.75	0.88	0.72	1.31	1.69
LM-WRC0616	3/8	0.44	1.5	0.75	1	0.91	1.63	1.94
LM-WRC0716	7/16	0.50	1.88	1	1.19	1.03	1.81	2.28
LM-WRC0816	1/2	0.50	1.88	1	1.19	1.13	1.91	2.28
LM-WRC0916	9/16	0.56	2.25	1.25	1.31	1.22	2.06	2.5
LM-WRC1016	5/8	0.56	2.38	1.25	1.31	1.34	2.06	2.5
LM-WRC1216	3/4	0.62	2.75	1.44	1.5	1.41	2.25	2.84
LM-WRC1416	7/8	0.75	3.12	1.62	1.75	1.49	2.44	3.16
LM-WRC1616	1	0.75	3.5	1.81	1.88	1.78	2.63	3.47
LM-WRC1816	1 1/8	0.75	3.88	2	2	1.91	2.81	3.59
LM-WRC2016	1 1/4	0.88	4.25	2.13	2.31	2.19	3.13	4.13
LM-WRC2216	1 3/8	0.88	4.53	2.31	2.38	2.31	3.13	4.19
LM-WRC02416	1 1/2	0.88	4.94	2.38	2.59	2.44	3.41	4.44
LM-WRC2616	1 5/8	1.00	5.31	2.62	2.75	2.66	3.63	4.75
LM-WRC2816	1 3/4	1.13	5.75	2.75	3.06	2.94	3.81	5.28
LM-WRC3216	2	1.25	6.44	3	3.38	3.23	4.44	5.88
LM-WRC3616	2 1/4	1.25	7.13	3.19	3.88	3.19	4.5	6.38
LM-WRC4016	2 1/2	1.25	7.69	3.44	4.13	3.69	4.05	6.63
LM-WRC4416	2 3/4	1.25	8.31	3.56	4.38	4.88	5.00	6.88
LM-WRC2816	3	1.50	9.19	3.88	4.75	4.69	5.88	7.63



*Maximum Proof Load is 2 times the Working Load Limit.
 *Minimum Ultimate Strength is 6 times the Working Load Limit.

ELECTRIC CHAIN HOIST

Suspension Type

- Single Speed Model
- Dual Speed Model



Specifications table

SINGLE SPEED (3 PHASE)

F(H)		1,000	2,000	3,000	5,000	10,000	15,000	20,000
Model Name		1F(H)	2F(H)	3F(H)	5F(H)	10FH	15FH	20FH
Standard Lift	(m)	3(6)			6			
Hoisting Speed	50Hz	7.1	6.8	4.1	2.8	2.8	1.8	1.4
	60Hz	8.5	8.2	4.9	3.3	3.3	2.2	1.6
Motor Output	50Hz	1.3			2.4		2.4x2	
	60Hz	1.6			2.9		2.9x2	
Link Chain	Dia. (mm)	φ7.1		φ10				
	No. of Falls	1	1	2	3	4	6	8
Rating		30% ED						
Power Cord Length		5m						

DUAL SPEED (3 PHASE)

FN(H)		2,000	3,000	5,000	10,000	15,000
Model Name		2FN(H)	3FN(H)	5FN(H)	10FNH	15FNH
Standard Lift	(m)	3(6)			6	6
Hoisting Speed	50Hz	6.8/1.7	4.0/1.0	2.8/0.7	2.8/0.7	1.8/0.45
	60Hz	8.2/2.1	4.8/1.2	3.3/0.8	3.3/0.8	2.2/0.55
Motor Output	50Hz	2.4/0.6			2.4/0.6x2	
	60Hz	2.9/0.7			2.9/0.7x2	
Link Chain	Dia. (mm)	φ10				
	No. of Falls	1	2	3	4	6
Rating		20% ED				
Power Cord Length		5m				

ELECTRIC CHAIN HOIST

Suspension Type

- Single Speed Model
- Dual Speed Model
- Single Phase Model



Specifications table

SINGLE SPEED (3 PHASE)

S(H)

Rated Load (kg)	250	500	1,000	2,000	3,000	5,000
Model Name	1/4S(H) ₂	1/2S(H) ₂	1S(H)	2S(H)	3S(H)	5S(H)
Standard Lift (m)	3(6)					
Hoisting Speed (m/min)	50Hz	10	7.2	4.6	2.3	1.5
	60Hz	12	8.5	5.5	2.8	1.1
Motor Output(kW)	50Hz	0.45	0.63	0.8	0.8	0.8
	60Hz	0.55	0.75	1.0	1.0	1.0
Link Chain	Dia. (mm)	φ6.3	φ6.3	φ7.1	φ7.1	φ7.1
	No. of	1	1	1	2	3
Rating	30% ED			25% ED		
Power Cord Length	5m					

DUAL SPEED (3 PHASE)

SN(H)

Rated Load (kg)	250	500	1,000	2,000
Model Name	1/4SN(H) ₂	1/2SN(H) ₂	1SN(H)	2SN(H)
Standard Lift (m)	3(6)			
Hoisting Speed (m/min)	50Hz	7.2/1.8	7.2/1.8	4.6/1.2
	60Hz	8.5/2.1	8.5/2.1	5.5/1.4
Motor Output (kW)	50Hz	0.32/0.08	0.63/0.16	0.8/0.2
	60Hz	0.38/0.1	0.75/0.19	0.1/0.25
Link Chain	Dia.(mm)	φ6.3	φ6.3	φ7.1
	No. of Falls	1	1	2
Rating	25% ED		20/10% ED	
Power Cord Length	5m			

All dimensions and specifications are subject to change without notice.

SINGLE PHASE

SS(H)₂, S(H)₁

Rated Load (kg)	250	500	1,000	2,000	3,000	5,000
Model Name	1/4SS(H) ₂	1/2SS(H) ₂	1S(H) ₁	2S(H) ₁	3S(H) ₁	5S(H) ₁
Standard Lift (m)	3(6)					
Hoisting Speed (m/min)	50Hz	5.0	3.6	2.3	1.1	0.8
	60Hz	6.0	4.3	2.8	1.4	0.9
Motor Output (kW)	50Hz	0.25	0.32	0.4	0.4	0.4
	60Hz	0.30	0.37	0.5	0.5	0.5
Link Chain	Dia.(mm)	φ6.3	φ6.3	φ7.1	φ7.1	φ7.1
	No. of Falls	1	1	2	3	5
Rating	25% ED			20% ED		
Power Cord Length	5m					

All dimensions and specifications are subject to change without notice.

Suspension Type

Dimensions

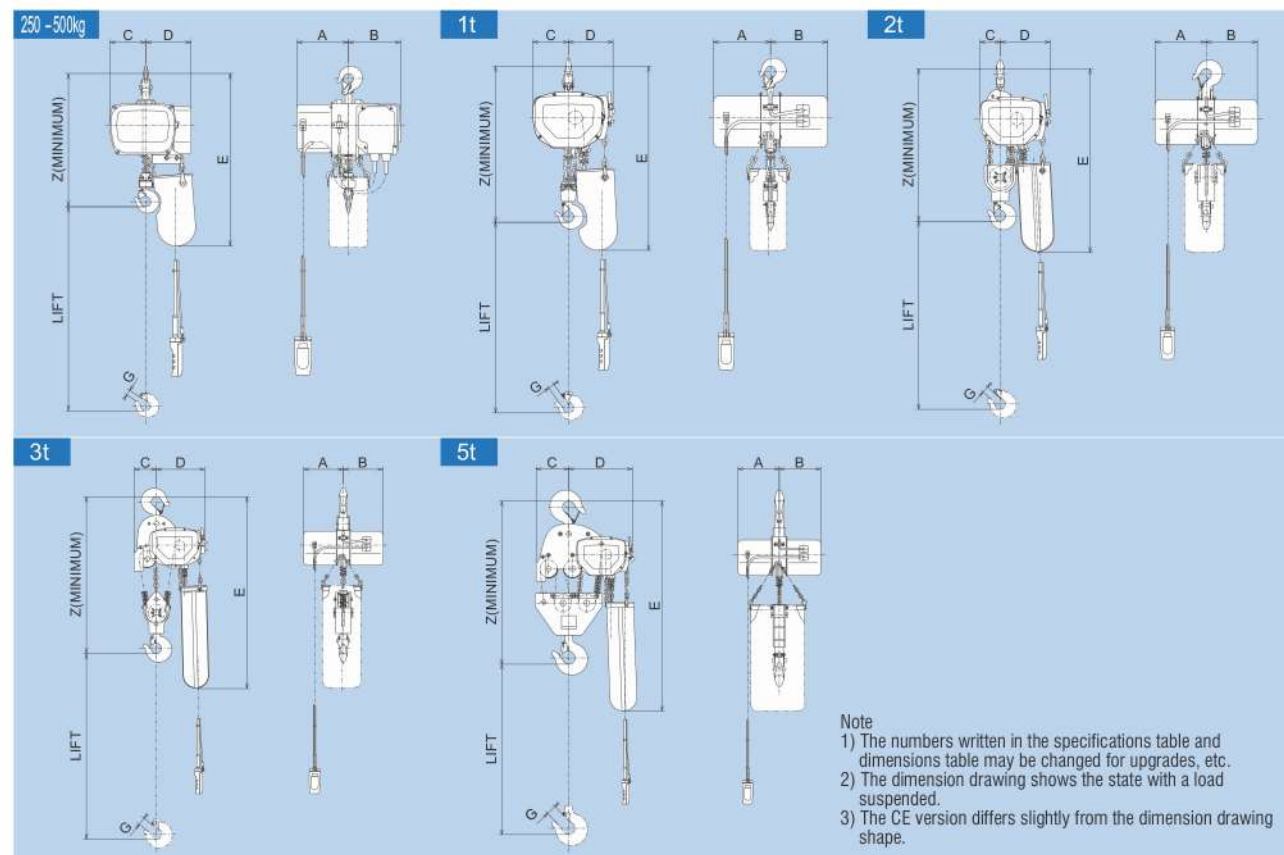

Note
 1) The numbers written in the specifications table and dimensions table may be changed for upgrades, etc.
 2) The dimension drawing shows the state with a load suspended.
 3) The CE version differs slightly from the dimension drawing shape.

Specifications table

SINGLE SPEED (3 PHASE)

Model Name	1/4S ₂	1/4SH ₂	1/2S ₂	1/2SH ₂	1S	1SH	2S	2SH	3S	3SH	5S	5SH
Rated Load (kg)	250	500	1,000	2,000	3,000	5,000						
Dimensions (mm)	Z	450	450	530	645	800	895					
	A	181	181	216	216	216	216					
	B	184	184	216	216	216	216					
	C	125	125	135	90	125	175					
	D	165	165	170	215	270	340					
	D(CE)	200	200	170	215	270	340					
	E	620	620	680	705	775	835	1,050	1,065	1,095		
G	19	19	23	26	42	48						
Approx. Weight (kg)	28	31	31	34	37	42	49	59	61	72	88	105

All dimensions and specifications are subject to change without notice.

DUAL SPEED (3 PHASE)

Model Name	1/4SN ₂	1/4SNH ₂	1/2SN ₂	1/2SNH ₂	1SN	1SNH	2SN	2SNH
Rated Load (kg)	250	500	1,000	2,000				
Dimensions (mm)	Z	450	450	530	645			
	A	183	183	216	216			
	B	210	210	246	246			
	C	125	125	135	90			
	D	185	185	170	215			
	D(CE)	200	200	170	215			
	E	620	620	680	705	775		
G	19	19	23	26				
Approx. Weight (kg)	33	36	36	39	42	47	54	64

All dimensions and specifications are subject to change without notice.

SINGLE PHASE

Model Name	1/4SS ₂	1/4SSH ₂	1/2SS ₂	1/2SSH ₂	1S ₁	1SH ₁	2S ₁	2SH ₁	3S ₁	3SH ₁	5S ₁	5SH ₁
Rated Load (kg)	250	500	1,000	2,000	3,000	5,000						
Dimensions (mm)	Z	450	450	530	645	800	895					
	A	181	181	246	246	246	246					
	B	210	210	246	246	246	246					
	C	125	125	135	90	125	175					
	D	165	165	170	215	270	340					
	D(CE)	200	200	170	215	270	340					
	E	620	620	680	705	775	835	1,050	1,065	1,095		
G	19	19	23	26	42	48						
Approx. Weight (kg)	34	37	34	37	39	44	51	61	63	74	90	107

All dimensions and specifications are subject to change without notice.

with Motorized Trolley-ET

This can be combined with a 4-point or 6-point pushbutton and used as a motorized trolley or overhead traveling crane.

Dimensions

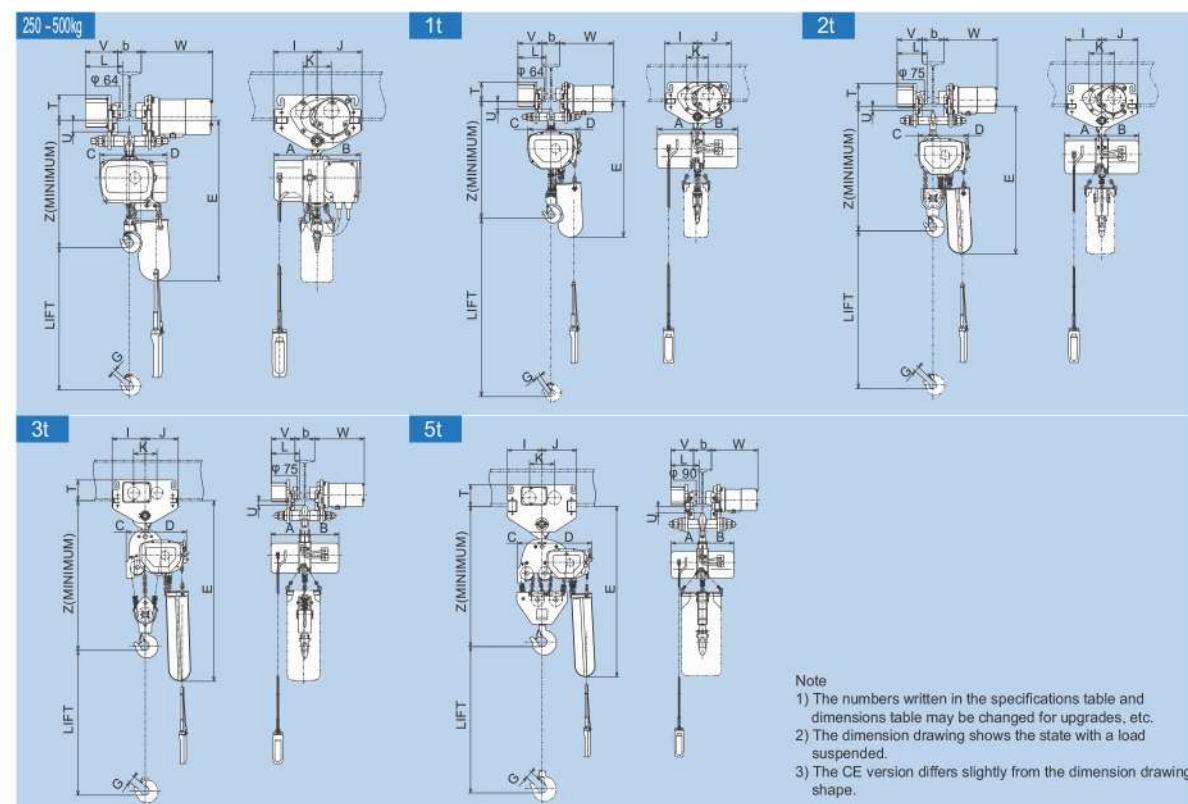

Specifications table

Chain Hoist Model Name	1/4S(H) ₂	1/4SN(H) ₂	1/2S(H) ₂	1/2SN(H) ₂	1S(H)	1SN(H)	2S(H)	2SN(H)	3S(H)	5S(H)
Trolley Type	1ET				2ET		3ET		5ET	
Rated Load (kg)	250		500		1,000		2,000		3,000	
Z	523	523	523	523	600	600	700	700	865	984
A	181	183	181	183	216	216	216	216	216	216
B	184	210	184	210	216	246	216	246	216	216
C	125	125	125	125	135	135	90	90	125	175
D	165	185	165	185	170	170	215	215	270	340
D'(CE)	200	200	200	200	170	170	215	215	270	340
E	693	693	693	693	750	750	770(840)		910(1,125)	1,170(1,200)
G	19	19	19	19	23	23	26	26	42	48
I	185						210	210	240	
J	190						210	210	240	
K	120						148	148	173	
L	182						200	203	219	
T	110						140	140	156	
U	38						18	16	34	
V	159						172	175	181	
W	303						313	316	323	
Min. Curve Radius (m)	1.5						1.8	2.0	3.0	
Applicable Beam Width b (mm)	75-125						100-150		125-175	
Approx. Weight (kg)	66(69)	71(74)	69(72)	74(77)	75(80)	80(85)	101(111)	108(116)	121(132)	174(191)

All dimensions and specifications are subject to change without notice.

Motorized trolley specifications table

Series Name	ET series				ST series		
Model Name	1ET	2ET	3ET	5ET	1ST	2ST	3ST
Working Load Limit (kg)	1,000	2,000	3,000	5,000	1,000	2,000	3,000
Traveling Speed (m/min)	10.5(21)				10.5		
Motor Output (kW)	0.14(0.27)				0.07	0.14	0.2
Applicable Beam Width b (mm)	75-125	100-150		125-175	75-125	100-150	
Rating	25%ED				25%ED		

with Motorized Trolley-ST

This can be combined with a 4-point or 6-point pushbutton and used as a motorized trolley or overhead traveling crane.

Dimensions

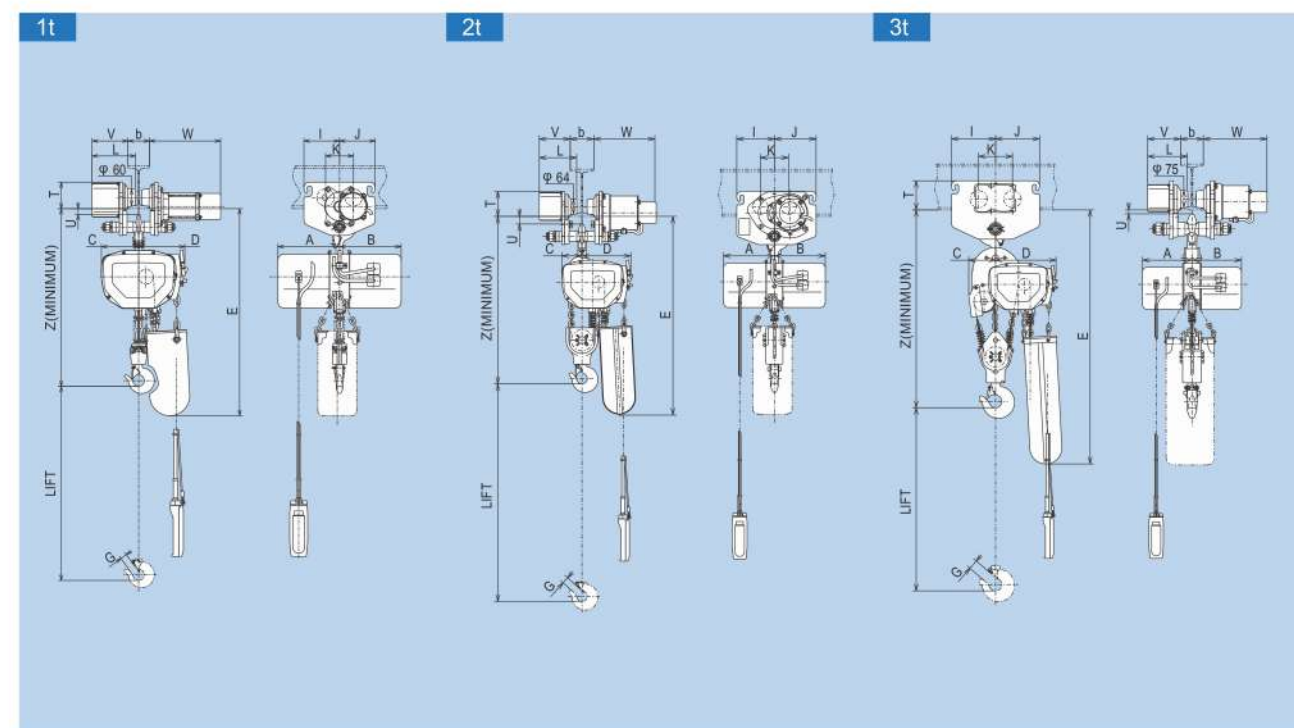

Specifications table

Chain Hoist Model Name	1S(H)	1SN(H)	2S(H)	2SN(H)	3S(H)
Trolley Type	1ST		2ST		3ST
Rated Load (kg)	1,000		2,000		3,000
Z	578	578	700	700	852
A	216	216	216	216	216
B	216	246	216	246	216
C	135	135	90	90	125
D, D'(CE)	170	170	215	215	270
E	730	730	772(842)		900(1,115)
G	23	23	26	26	42
I	125		160		192
J	125		177		192
K	98		120		148
L	156		163		180
T	101		119		140
U	18		19		5
V	130		135		145
W	255		270		280
Min. Curve Radius (m)	1.8		2.5		3.0
Applicable Beam Width b (mm)	75-100		100-150		100-150
Approx. Weight (kg)	60(65)	65(70)	86(96)	91(101)	109(120)

All dimensions and specifications are subject to change without notice.

Stainless steel lifting chain

EXCEL®

Material : AISI 316L, grade 5
Safety factor : MBL equals 4 x WLL.
Finish : Polished
Certification : 2.1 2.2 3.1 MTC²

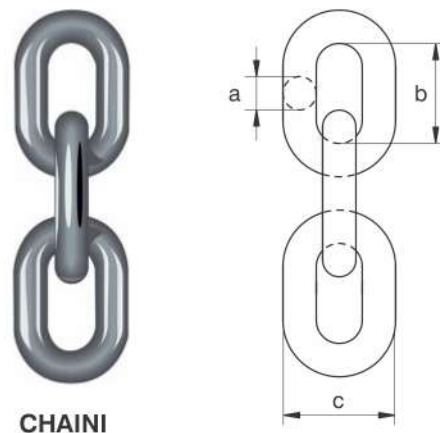

CHAIN1

diameter		working load limit	length inside	width outside	links per meter	length per drum	weight per mtr
mm	inch	t	b mm	c mm		m	kg
6	7/32	0.7	18	21	55.56	100	0.78
8	5/16	1.2	24	29	41.67	100	1.3
10	3/8	1.6	30	34	33.33	100	2.14
13	1/2	2.7	39	45	25.64	100	3.64

EXCEL® Stainless steel eye sling hook

EXCEL®

Material : AISI 316L, grade 5
Safety factor : MBL equals 4 x WLL
Finish : Polished
Certification : 2.1 2.2 3.1 MTC²



CSOI

for chain diameter		working load limit	length	diameter inside eye	width opening	thickness	width	diameter eye outside	width outside	length	width	thickness	weight each
mm	inch	t	a mm	b mm	c mm	d mm	e mm	f mm	g mm	h mm	i mm	j mm	kg
6	7/32	0.7	84	23	26	15	20	43	72	114	10	6	0.28
7-8	1/4 - 5/16	1.2	103	26	30	20	24	51	87	139	12	8	0.56
10	3/8	1.6	128	35	33	24	29	65	106	172	15	10	1.09
13	1/2	2.7	152	41	37	32	39	77	133	209	18	12	1.98

EXCEL® Stainless steel omega link

EXCEL®

Material : AISI 316L, grade 5
Safety factor : MBL equals 4 x WLL.
Finish : Polished
Certification : 2.1 2.2 3.1

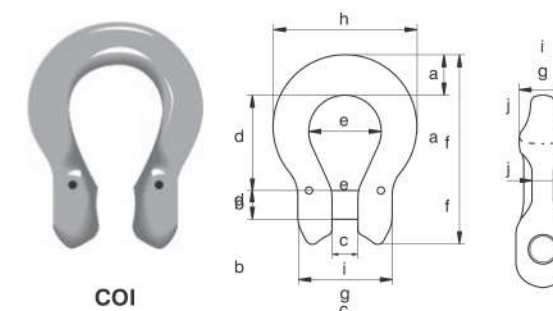

COI

for chain diameter		working load limit	width	diameter pin	width	length inside	width bow	length outside	thickness	width outside	width outside	thickness	weight each
mm	inch	t	a mm	b mm	c mm	d mm	e mm	f mm	g mm	h mm	i mm	j mm	kg
5	3/16	0.5	14	6	7	26	20	53	13	41	28	6	0.07
6	7/32	0.7	14	8	7	25	20	53	13	41	28	6	0.07
7-8	1/4 - 5/16	1.2	20	9	9	34	24	71	16	55	32	8	0.18
10	3/8	1.6	19	13	12	40	31	82	17	63	42	11	0.28
13	1/2	2.7	25	16	15	51	40	106	20	84	54	14	0.64

EXCEL® Stainless steel connecting link

EXCEL®

Material : AISI 316L, grade 5
Safety factor : MBL equals 4 x WLL
Finish : Polished
Certification : 2.1 2.2 3.1

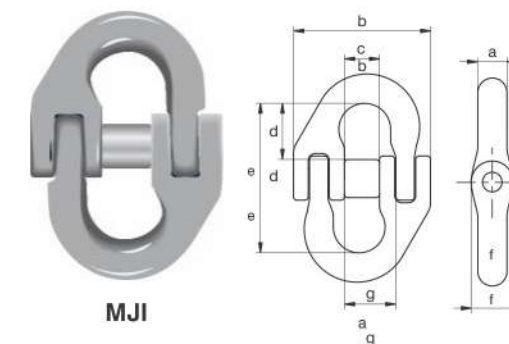

MJI

for chain diameter		working load limit	diameter	width outside	width inside	length inside	length inside	diameter eye	width inside	weight each
mm	inch	t	a mm	b mm	c mm	d mm	e mm	f mm	g mm	kg
6	7/32	0.7	8	42	11	20	52	11	15	0.09
7-8	1/4 - 5/16	1.2	9	53	14	20	55	13	19	0.16
10	3/8	1.6	10	66	18	23	64	18	23	0.28
13	1/2	2.7	14	83	21	32	85	24	28	0.64

Stainless Steel Master Link

EXCEL®

Material : AISI 316L, grade 5
Safety factor : MBL equals 4 x WLL.
Finish : Polished
Certification : 2.1 2.2 3.1 MTC²

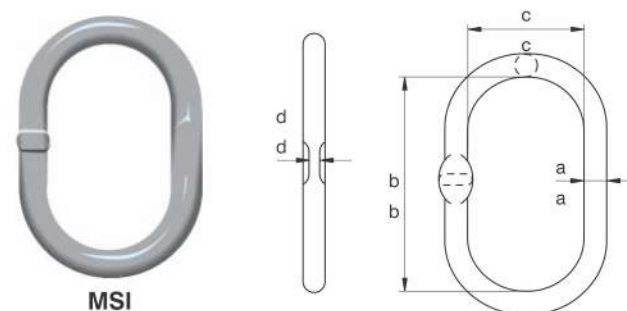

diameter chain 1 leg	diameter chain 2 legs		working load limit	diameter a	length inside b	width inside c	thick- ness d	weight each
	$\beta < 45^\circ$	$\beta < 60^\circ$						
mm	mm	mm	t	mm	mm	mm	mm	kg
6	6	6	1	13	110	60	6	0.34
8	6	8	1.25	16	110	60	6	0.53
10	8	10	2	18	135	75	8	0.82
13	10	13	3.2	22	160	90	10	1.45
16	13	16	5	26	180	100	13	2.29

In inch

diameter chain 1 leg	diameter chain 2 legs		working load limit	diameter a	length inside b	width inside c	thick- ness d	weight each
	$\beta < 45^\circ$	$\beta < 60^\circ$						
inch	inch	inch	t	inch	inch	inch	inch	lbs
$\frac{7}{32}$	$\frac{7}{32}$	$\frac{7}{32}$	1	$\frac{1}{2}$	$4 \frac{11}{32}$	$2 \frac{3}{8}$	$\frac{1}{4}$	0.75
$\frac{5}{16}$	$\frac{7}{32}$	$\frac{5}{16}$	1.25	$\frac{5}{8}$	$4 \frac{11}{32}$	$2 \frac{3}{8}$	$\frac{1}{4}$	1.17
$\frac{3}{8}$	$\frac{5}{16}$	$\frac{3}{8}$	2	$\frac{23}{32}$	$5 \frac{5}{16}$	$2 \frac{15}{16}$	$\frac{5}{16}$	1.81
$\frac{1}{2}$	$\frac{3}{8}$	$\frac{1}{2}$	3.2	$\frac{7}{8}$	$6 \frac{5}{16}$	$3 \frac{3}{4}$	$\frac{13}{32}$	3.20
$\frac{5}{8}$	$\frac{1}{2}$	$\frac{5}{8}$	5	$1 \frac{1}{32}$	$7 \frac{3}{32}$	$3 \frac{15}{16}$	$\frac{9}{16}$	5.05

Stainless Steel bow Shackle with Screw Pin

EXCEL®

Material : AISI 316L, grade 5
Safety factor : MBL equals 5 x WLL.
Finish : Polished
Certification : 2.1 2.2 3.1
Note : Marked with WLL and CE

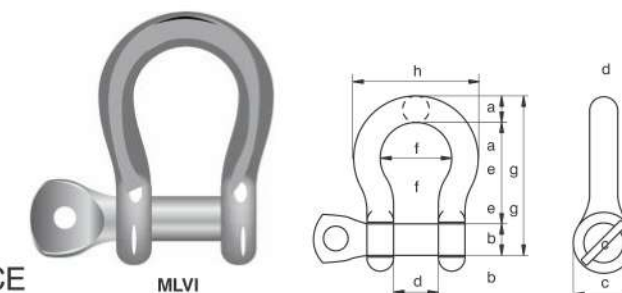

working load limit	diameter bow	diameter pin	diameter eye	width inside	length inside	width bow	length	width	weight each
t	a mm	b mm	c mm	d mm	e mm	f mm	g mm	h mm	kg
0.4	8	8	16	16	32	25	56	41	0.06
0.6	10	10	19	20	40	28	67	48	0.12
0.9	12	12	24	25	48	36	79	59	0.2
1.5	13	16	31	24	52	35	87	60	0.32
2.5	16	20	38	28	64	42	108	71	0.58
3	19	22	44	32	72	50	125	87	0.96
4	22	25	50	37	74	60	145	101	1.46
6	25	30	57	40	94	67	157	115	2.09

Stainless steel dee shackle with screw pin

EXCEL®

Material : AISI 316L, grade 5
Safety factor : MBL equals 5 x WLL.
Finish : Polished
Certification : 2.1 2.2 3.1 CE
Note : Marked with WLL and CE

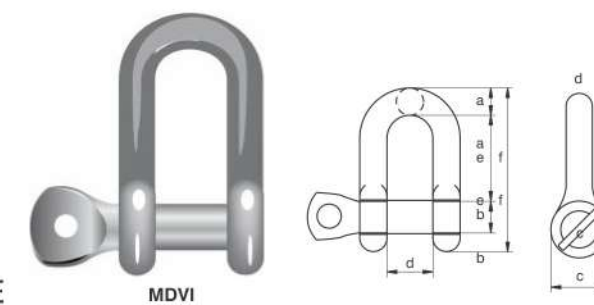

working load limit	diameter bow	diameter pin	diameter eye	width inside	length inside	length	weight each
t	a mm	b mm	c mm	d mm	e mm	f mm	kg
0.4	8	8	16	16	32	52	0.06
0.6	10	10	19	20	40	64	0.11
0.9	12	12	24	25	48	78	0.19
1.5	13	16	31	24	52	90	0.3
2.5	16	20	38	28	64	110	0.57
3	19	22	44	32	72	124	0.9
4	22	25	50	37	74	134	1.33
6	25	30	57	40	94	162	1.98

FULL BODY HARNESS

A Full Body Harness is the ideal body wear that should be worn by a worker, since it distributes the force of impact incurred in the event of a fall evenly on the thighs and torso region of the body.

The material of construction of the webbing of RV Industries Harnesses is Polyester. Since this has the least elongation properties as compared to other materials, the Harness does not stretch dangerously when subjected to a fall. The wearer hence does not risk slipping out of the Harness.



PREMIUM RANGE



PREMIUM RANGE



PREMIUM RANGE



TOWER HARNESS



SIT HARNESS



HARNESS WITH RESCUE STRAP



HARNESS WITH WAIST BELT



HARNESS WITH CHEST BELT



HARNESS WITH TEXTILE LOOPS

LANYARDS

The Fall Arrest Lanyards incorporate a shock absorbing element which is capable of limiting the force felt on the body of the worker to less than 6kN.

Depending upon the specific usage, Lanyards are classified as follows:

Work Positioning Lanyards, Restraint Lanyards, Fall Arrest Lanyards & Forked Lanyards.

SALVATOR offers an exhaustive range of lanyards made of Twisted rope, Braided rope or Webbing, and different Connector combinations, as per the needs of the user.



BRAIDED ROPE RESTRAINT LANYARD



EXTENDABLE RESTRAINT LANYARD



ENERGY ABSORBING WEBBING (44MM) LANYARDS



FORKED LANYARDS WITH ENERGY ABSORBER



WORK POSITIONING LANYARD



WORK POSITIONING LANYARD

RETRACTABLE BLOCK

One of the biggest challenges in fall protection is when the anchorage is too high to access and the clearance distance is too small.

SALVATOR Retractable Fall Arrester Blocks provide an ideal solution for such a problem.



MINI MOBILE RETRACTABLE (MOBILOCK) BLOCK



POLYMER CASING WITH STAINLESS STEEL WIRE ROPE



TWIN RETRACTABLE BLOCK



TWIN LEGGED RETRACTABLE LANYARD



POLYMER CASING WITH 25MM WEBBING LANYARD

CONFINED SPACE

A Particularly challenging area of activity is when the worker is required to move into confined spaces.

SALVATOR provides equipment that allows easy overhead access into and retrieval of personnel and material from such confined space areas.

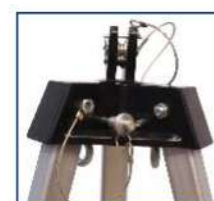

SINGLE PULLEY TRIPOD



DOUBLE PULLEY TRIPOD



WINCH



TRIPOD KIT BAG

HOOKS & CONNECTORS

The **SALVATOR** range of Hooks and Connectors comes with the following special features:

- ▶ Are openable by minimum 2 deliberate consecutive manual actions.
- ▶ A range of Manual and Automatic Locking Hooks and Connectors.
- ▶ Tested for both Gate Functions and Gate Resistance.
- ▶ Tested for corrosion resistance for minimum 72 hours of salt spray testing.
- ▶ Certified as per EN Norms.



STEEL SCREW
LOCKING KARABINER



STEEL QUARTER TURN
LOCKING KARABINER



STEEL TRIPLE ACTION
LOCKING KARABINER



STEEL SNAP HOOK



SWIVEL HOOK
WITH INDICATOR



STEEL SCAFFOLD
HOOK



STEEL TOWER HOOK



ALUMINIUM DOUBLE
LOCKING KARABINER



ALUMINIUM QUARTER
TURN LOCKING HOOK



REBAR HOOK

ANCHORAGES

Anchorage devices which can be easily installed over a variety of structures to provide a safe anchorage points for working at height where needed.

SALVATOR Anchorage devices and connectors are thoroughly tested and engineered to adapt to nearly every anchorage need where connection of a fall arrest system to a 15kN anchor point is necessary.

Whether you choose to tie off to your anchor point or an I-beam clamp, **SALVATOR** has the variety to get the job done.

SALVATOR offers a wide range of Anchorage Solutions in Webbing, Steel rope and Metal.

All these Anchorages Comply to the Latest European Standard EN 795:2012.

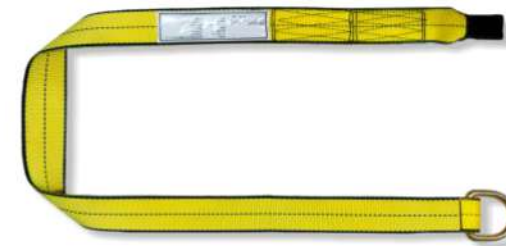

ANCHORAGE WEBBING SLING

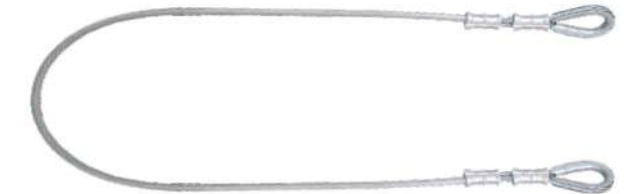

ANCHORAGE STEEL WIRE ROPE SLING



STEEL POINT ANCHOR



STAINLESS STEEL CHEMICAL POINT ANCHOR



HINGE ANCHOR WITH SWIVEL D-RING



FLANGE ANCHOR

TEMPORARY ANCHORAGE LINE SYSTEM

SALVATOR provides a vast range of Temporary Horizontal & Vertical Anchorage Line Systems which are extremely easy to carry & install. These lifelines provide a suitable and safe anchorage to the user whenever needed.



GUIDED TYPE FALL ARRESTER SYSTEM ON FLEXIBLE ANCHORAGE LINES



TWISTED ROPE ANCHORAGE LINE



BRAIDED ROPE ANCHORAGE LINE



TEMPORARY HORIZONTAL LIFELINE

ROPE ACCESS & RESCUE

Rope Access technique of movement on a rope should only be used when traditional access systems cannot be installed. The basic rope access equipment should be used with a fall protection system.

Rescue technique is used in an emergency hence it is naturally the most sensitive. This intervention can be performed by the user him/ herself, if he/she is conscious and has the necessary equipment for self-extraction, or by a helper.

In this situation it is necessary to be able to reach the victim, release him/ her in complete safety and move the person upwards or downwards.



GRIP DESCENDER



ASCENDER HANDLE



FIGURE OF 8



STEEL PULLEY DOUBLE SIDE ATTACHMENT



ALUMINIUM DOUBLE PULLEY DOUBLE SIDE ATTACHMENT



ROPE CLAMP



PILOT CHAIR

SAFETY GARMENTS

SALVATOR has dedicated its most valuable resources to the development and innovation of Safety Garments, and in-turn we have won the confidence and trust of our customer. We supply to some of the most prestigious international names in bulk buying and we have a strong equity with domestic consumers as well.

Our stalwart value are-consistent quality, competitive pricing and punctually meeting the deadlines of our customers.



FLAME RETARDANT



HIGH VISIBILITY



FR DENIM



ALUMINIUM WORKWEAR



UNIVERSAL WORKWEAR





**Company : The old burj Al Arab Road , Km 18,
Next to the khatam Al-morsalin mosque
Office : Alex.Matrouh st.,- Al hadidi Tower,
above the Housing and Development Bank
Dekheila - Alexandria**



**Web : www.msgegypt.com
E-mail : info@msgegypt.com
Mob : 0104 045 40 18**

SINFINITY
 CERTIFICATION-INSPECTION-TRAINING -TESTING

Certificate

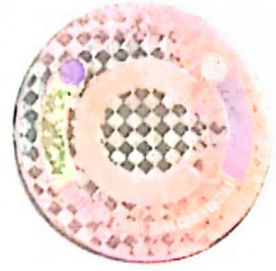

**INFINITY CERT INTERNATIONAL CERTIFY THAT
 THE ENVIRONMENTAL MANAGEMENT SYSTEM OF
 MSG FOR PETROLEUM SUPPLIES AND SERVICES**

ALEX.MATROUH ST., AL HADIDI TOWER, DEKHEILA , ALEXANDRIA, EGYPT.

HAS BEEN ASSESSED AND FOUND TO BE IN CONFORMANCE TO THE FOLLOWING STANDARD:

ISO 14001:2015

FOR THE FOLLOWING ACTIVITIES

**SUPPLYING AND TRADING OF PETROLEUM TOOLS AND EQUIPMENT
 PROVISION OF INDUSTRIAL ENGINEERING SERVICES INSPECTION**

EA CODE: 34

CERTIFICATE REGISTRATION NO. EG180924-1B

DATE OF INITIAL REGISTRATION:	18	SEPTEMBER	2024
ISSUE DATE:	18	SEPTEMBER	2024
EXPIRY DATE:	17	SEPTEMBER	2025
RECERTIFICATION DUE:	17	SEPTEMBER	2027



Marketing Office: 4690 182 - 184 High Street North East Ham London EG 2JA.Uk
 Company No: 14380751
 Critical location : BUILDING 221, 3rd district, 6th October- Giza - Egypt.
 E-mail: info@infinitycert.com
 Website: www.infinitycert.com

Hany Osman

Business Assurance at ICI

This Certificate is Only Valid if It is Available/Valid On ICI Website At <http://infinitycert.com>
 In case if Surveillance/Recertification Audit is not allowed to be conducted on or before the specified date: the Certificate shall be Suspended/Withdrawn.
 The certificate remains the property of Infinity Cert international, to whom it must be returned upon request.

VALIDITY OF THIS CERTIFICATE IS SUBJECT TO SUCCESSFUL COMPLETION OF SURVEILLANCE AUDIT ON OR BEFORE DUE DATE.

SINFINITY
CERTIFICATION-INSPECTION-TRAINING-TESTING

Certificate

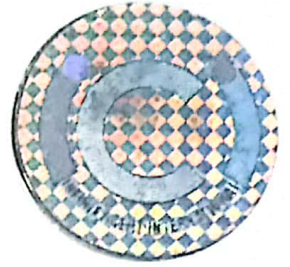

**INFINITY CERT INTERNATIONAL CERTIFY THAT
THE OCCUPATIONAL HEALTH AND SAFETY MANAGEMENT SYSTEM OF
MSG FOR PETROLEUM SUPPLIES AND SERVICES**

ALEX.MATROUH ST., AL HADIDI TOWER, DEKHEILA , ALEXANDRIA, EGYPT.

HAS BEEN ASSESSED AND FOUND TO BE IN CONFORMANCE TO THE FOLLOWING STANDARD:

ISO 45001:2018

FOR THE FOLLOWING ACTIVITIES

**SUPPLYING AND TRADING OF PETROLEUM TOOLS AND EQUIPMENT
PROVISION OF INDUSTRIAL ENGINEERING SERVICES INSPECTION**

EA CODE: 0110

CERTIFICATE REGISTRATION NO. EG180924-1C

DATE OF INITIAL REGISTRATION:	18	SEPTEMBER	2024
ISSUE DATE:	18	SEPTEMBER	2024
EXPIRY DATE:	17	SEPTEMBER	2025
RECERTIFICATION DUE:	17	SEPTEMBER	2027



Hany Osman

Business Assurance at ICI

Marketing Office: 4690 182 - 184 High Street North East Ham London E9 2JA Uk
Company No: 14380751
Critical location : BUILDING 221, 3rd district, 6th October- Giza - Egypt.
E-mail: Info@infinitycert.com
Website: www.infinitycert.com

This Certificate is Only Valid if It is Available/Valid On ICI Website At <http://infinitycert.com>
In case if Surveillance/Recertification Audit is not allowed to be conducted on or before the specified date: the Certificate shall be Suspended/Withdrawn.
The certificate remains the property of Infinity Cert international, to whom it must be returned upon request.

VALIDITY OF THIS CERTIFICATE IS SUBJECT TO SUCCESSFUL COMPLETION OF SURVEILLANCE AUDIT ON OR BEFORE DUE DATE.